



SIGMA PUMPY HRANICE



SELF PRIMING PUMPS

SVA

SIGMA PUMPY HRANICE, s.r.o.

Tovární 605, 753 01 Hranice, Czech Republic

tel.: +420 581 661 111, fax: +420 581 602 587

Email: sigmahra@sigmahra.cz

426	16.05
2.98	

Self Priming Horizontal Pumps SVA

Applications

The self priming side channel rotary pumps of SVA range are intended to pump drinking or service water without mechanical impurities up to 90°C.

These small side-channel pumps are spread broadly, especially they are suitable for domestic water supply pumps. They are used for water supply in housings, cottages, for spray irrigation of gardens and anywhere else in the case that suction head including losses in pipeline does not exceed 8m.

The pumps are used to handle flammable liquids of I-IV class. For this purpose the sizes 20 and 32 are equipped with mechanical seal.

It is possible to use these pumps also for pumping oils of kinematic viscosity up to 37 mm².s⁻¹.

Description

The pumps of SVA range are of rotary, self priming, side-channel, horizontal design coupled with flexible coupling to driving motor.

The pump consists of suction body, discharge body, suction insert, discharge insert, bearing housing, stuffing box cover, shaft with impellers and bearings.

The suction branch is arranged above horizontal axis of the pump so that the pump is always flooded with pumped liquid. The suction body is equipped with filling plug and drain plug. The discharge branch is pointed upward vertically. The suction and delivery inserts including impellers in number depending on the pressure required are put between the suction body and the discharge body. This subassembly is clamped with clamping bolts. The shaft at suction side is supported on sliding bush (bearing) which is cooled with pumped liquid. The shaft at discharge side is supported on ball bearing. The shaft is sealed with gland rope packing, that is pressed with stuffing box cover and two bolts, or with mechanical seal.

The pumps are supplied with counterflanges including sealings and bolts.

The pumps 25-SVA-ME and 32-SVA-ME are of close-coupled design without standard base plate.

The pumps 32-SVA-ME are assembled from:

- self priming pump
- connecting piece
- electric motor

The connecting piece makes connection of the pump to the electric motor with flexible coupling possible and at the same time it serves as foot of the "monoblock pumping unit". The pump is driven with electric motor size of which depends on number of pump stages.

Direction of Rotation

The pumps of SVA range are counterclockwise turning unit viewing from drive side.

Material

The suction body, the discharge body, the suction and discharge inserts, the bearing housing, the stuffing box cover and the flanges are made from grey cast iron, the impellers are made from brass and the shaft is made from structural steel. The sliding bush is made from sintered metal. Gland packing rope or mechanical seal is made from material depending on pumped liquid.

Accessories

The pumps are supplied with counterflanges including sealings and bolts. Holes in suction and discharge body for connection of pressure gauge or vacuum gauge are plugged.

Range of Delivery

The pumps can be supplied in several ranges following acc. to Czech standard ČSN 110021.

- range 1 - the pump only with bare end shaft
- range 9 - the pump coupled with complete flexible coupling to electric motor mounted on common base plate

To customer's special order we can supply:

- range 2 - the pump with complete flexible coupling
- range 3 - the pump with complete flexible coupling and with common base plate for pump and electric motor, but without the motor
- The pumps 25, 32-SVA-ME of close-coupled design without standard base plate.

When ordering, please advice:

- characteristic of application
- kind and temperature of pumped liquid
- size and pump type
- operating voltage

Informative Sectional Drawing of the Pump-20,25,32-SVA - with Gland Packing

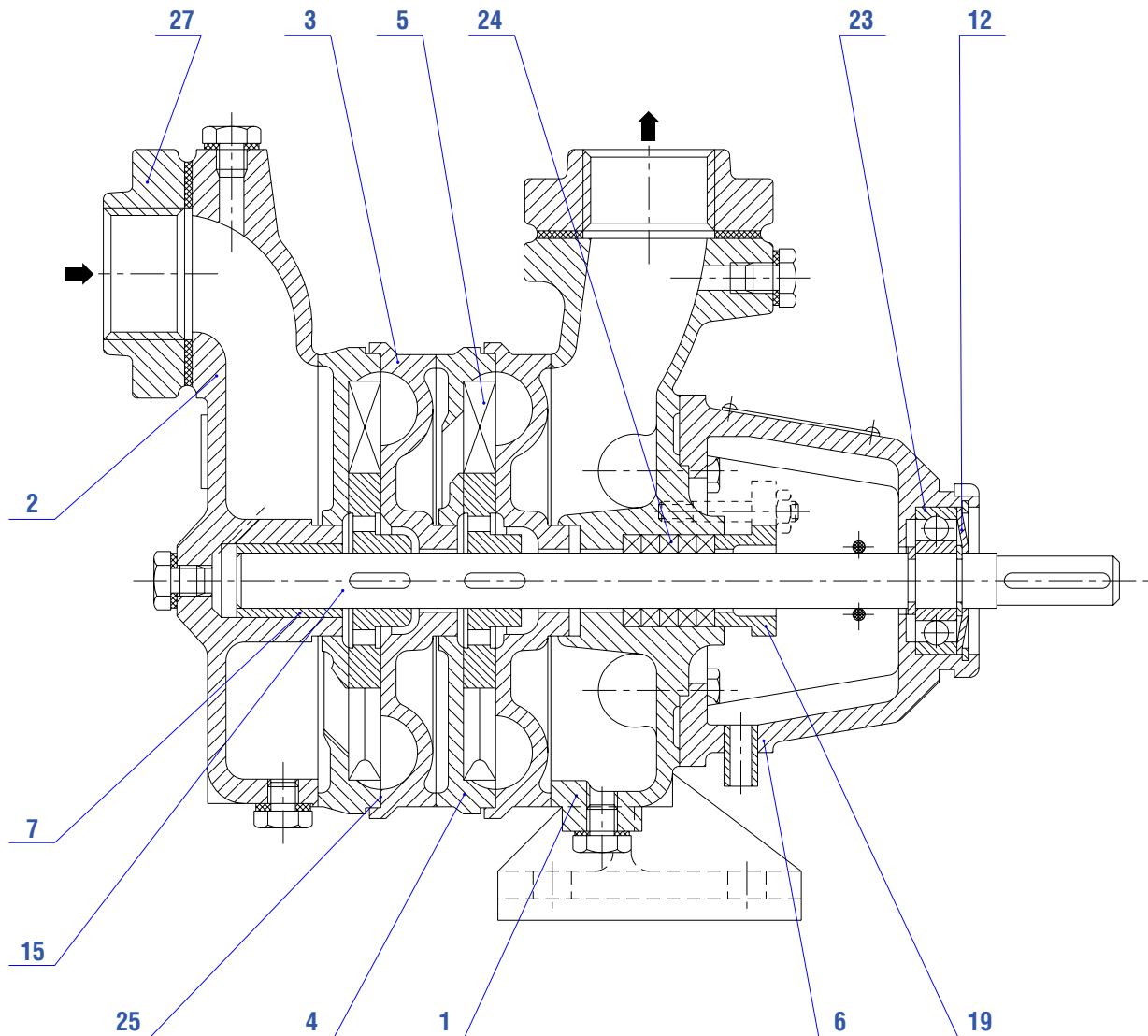

- | | | | |
|---|------------------|----|---------------------|
| 1 | Discharge body | 12 | Cap |
| 2 | Suction body | 15 | Shaft |
| 3 | Discharge insert | 19 | Gland packing cover |
| 4 | Suction insert | 23 | Bearing |
| 5 | Impeller | 24 | Gland packing rope |
| 6 | Bearing housing | 25 | Sealing |
| 7 | Sliding bush | 27 | Flange |

Self Priming Horizontal Pumps SVA

Informative Sectional Drawing of the Pump-20,32-SVA -with Mechanical Seal

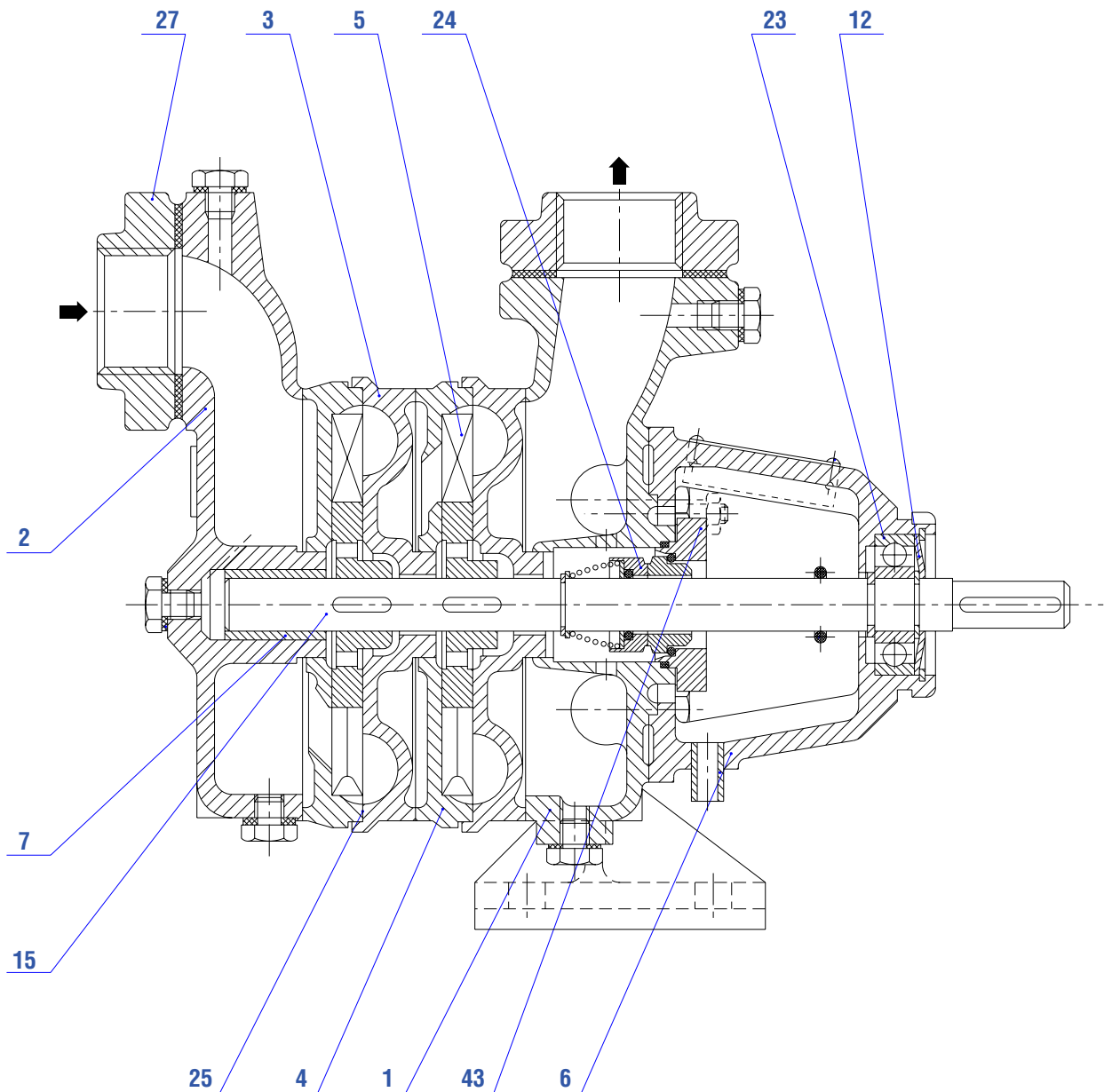

1	Discharge body	12	Cap
2	Suction body	15	Shaft
3	Discharge insert	23	Bearing
4	Suction insert	24	Mechanical seal
5	Impeller	25	Sealing
6	Bearing housing	27	Flange
7	Sliding bush	43	Mechanical seal cover

Self Priming Horizontal Pumps SVA

Informative Sectional Drawing of the Pump - 40-SVA

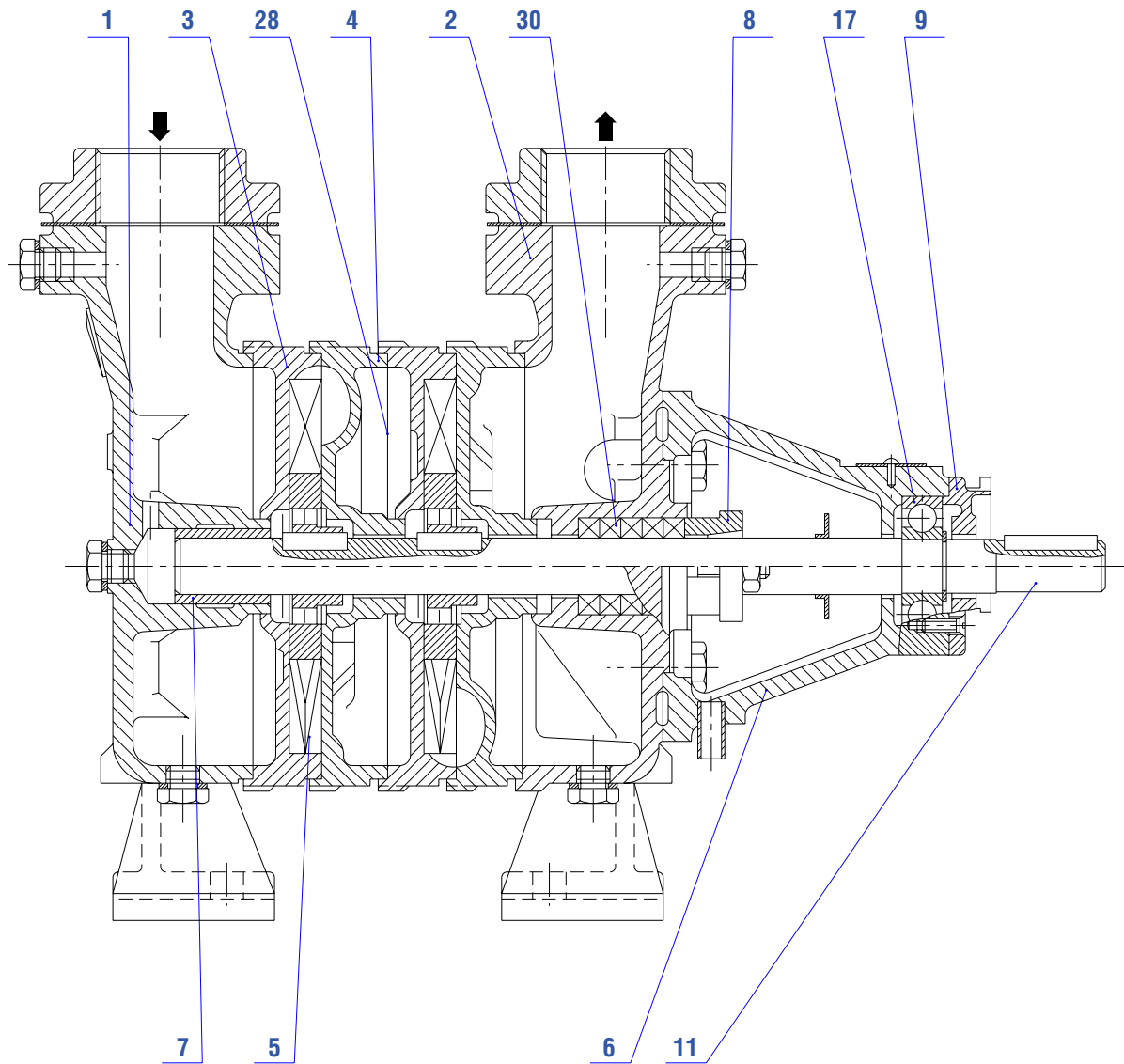

1	Discharge body	8	Stuffing box cover
2	Suction body	9	Cap
3	Discharge insert	11	Shaft
4	Suction insert	17	Bearing
5	Impeller	28	Sealing
6	Bearing housing	30	Gland packing rope
7	Sliding bush		

Informative Sectional Drawing of the Pumping Unit type 25, 32-SVA-ME with Gland Packing

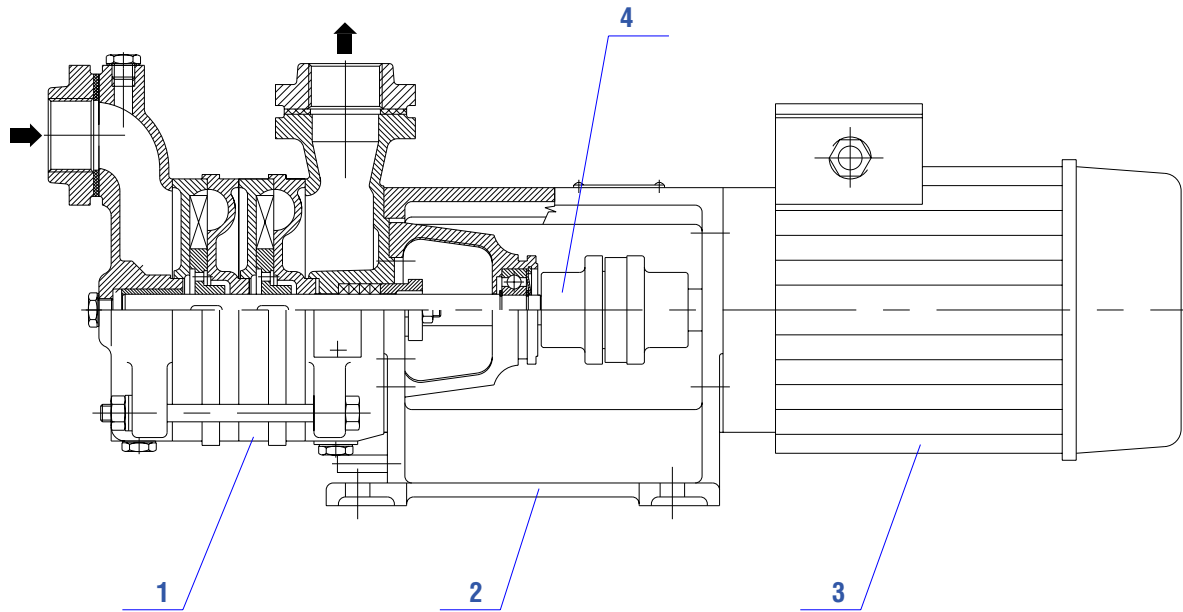

1. Pump
2. Connecting piece
3. Electric motor
4. Coupling

Informative Sectional Drawing of the Pumping Unit type 25, 32-SVA-ME with Mechanical Seal

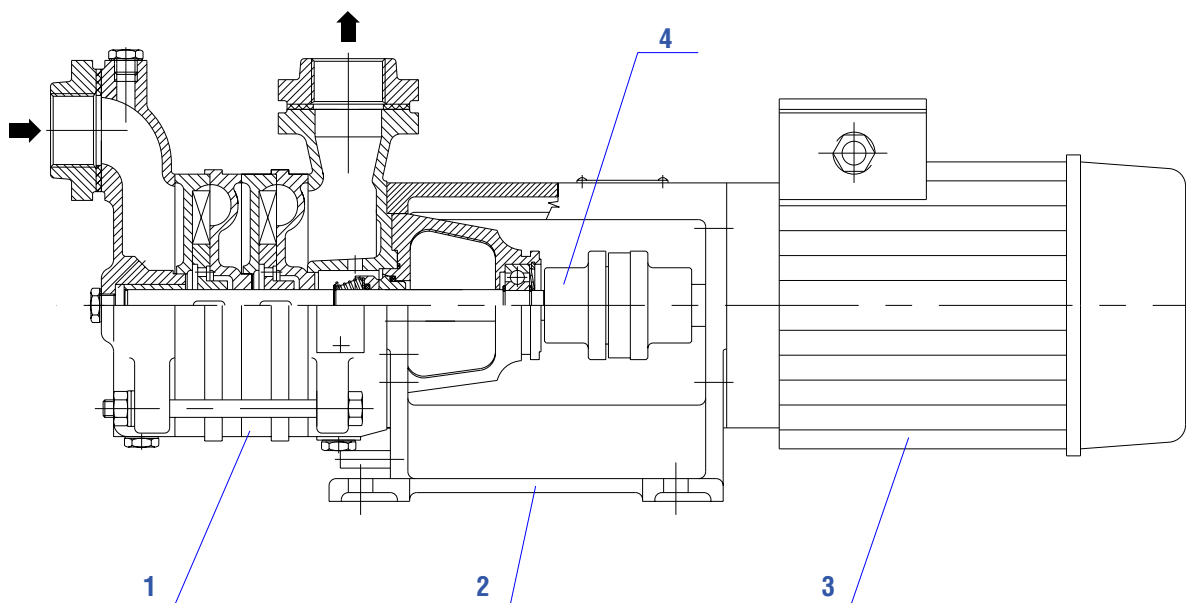

Self Priming Horizontal Pumps SVA

Dimensional Drawing of 40-SVA

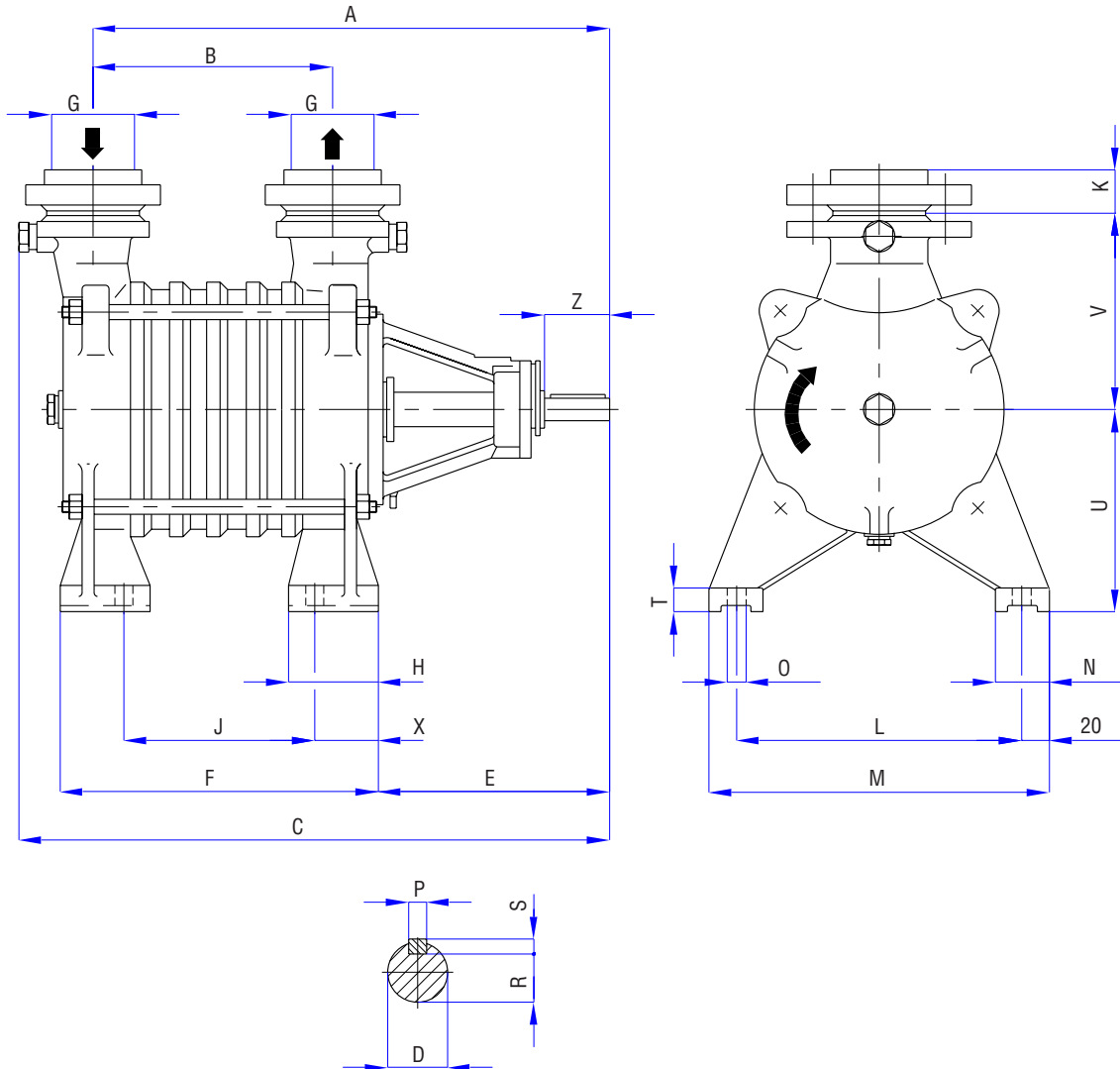

Pump	A	B	C	D	E	F	G	H	J	K	L	M	N	O	P	R	S	T	U	V	X	Z
40-SVA-1'	301	115	353	18	163	155	1 1/2"	60	77	29	150	190	40	12	6	14.5	6	18	132	128	42	40
40-SVA-2'	351	165	403			205			127													
40-SVA-3'	401	215	453			255			177													

Self Priming Horizontal Pumps SVA

Dimensional Drawing of Pumping Unit type 25, 32-SVA-ME

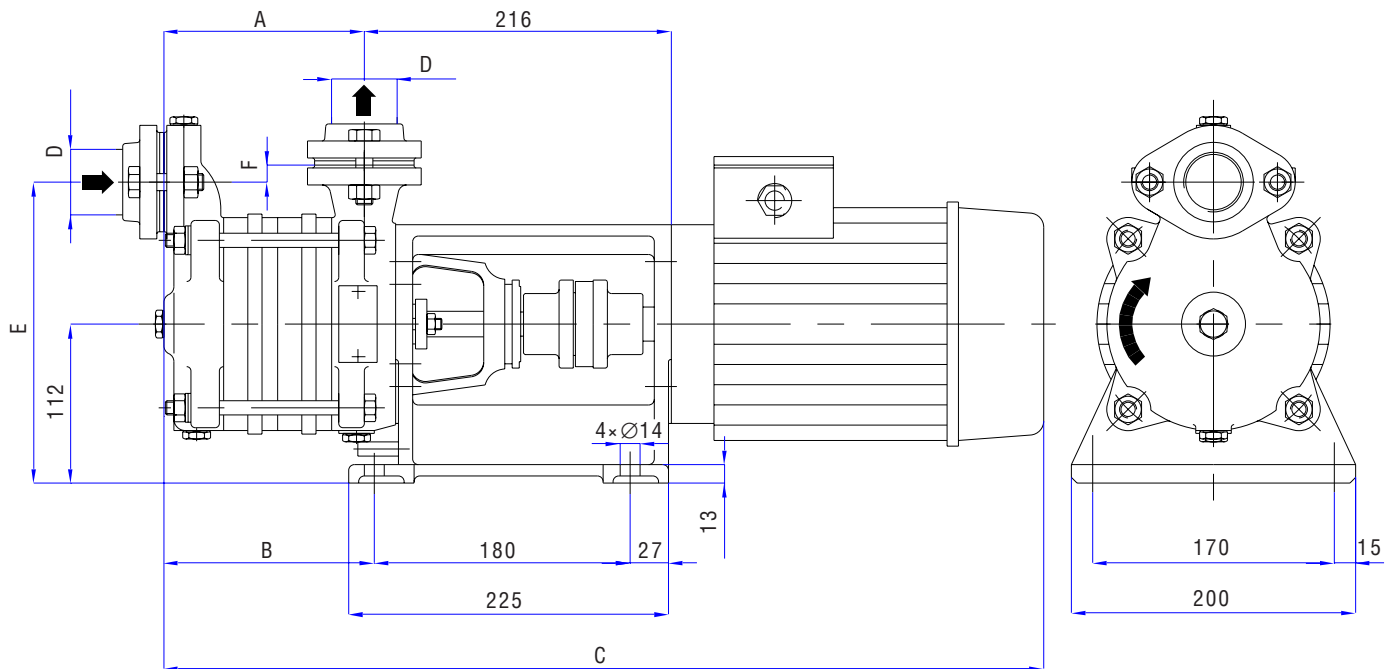

Pump	A	B	C	D	E	F
25-SVA-1'	98	104	561	G1"	202	10
25-SVA-2'	136	142	656	G1"	202	10
25-SVA-3'	174	180	694	G1"	202	10
32-SVA-1'	103	118	575	G1 1/4"	212	12
32-SVA-2'	141	156	670	G1 1/4"	212	12
32-SVA-3'	179	194	708	G1 1/4"	212	12

Self Priming Horizontal Pumps SVA

Performance Table of the Pumps SVA

Pump type	Brach-DN suction/discharge	Capacity Q (l.s ⁻¹)	Head H (m)	Power input (kW)	Possibility of design with mechanical seal	Weight of bare end shaft pump (kg)
20-SVA-1 ⁺ 20-SVA-2 ⁺ 20-SVA-3 ⁺	25/25	0.33 - 0.58	13 - 9 27 - 17 39 - 21	0.25 - 0.22 0.44 - 0.34 0.55 - 0.4	yes	8 10 12
25-SVA-1 ⁺ 25-SVA-2 ⁺ 25-SVA-3 ⁺	25/25	0.5 - 1	28 - 11 52 - 20 78 - 30	0.68 - 0.35 1.18 - 0.65 1.74 - 0.94	no	13.5 16 18.5
32-SVA-1 ⁺ 32-SVA-2 ⁺ 32-SVA-3 ⁺	32/32	0.83 - 1.33	31 - 12 63 - 28 91 - 38	0.98 - 0.6 1.92 - 1.2 2.65 - 1.65	yes	14.5 17.5 20.5
40-SVA-1 ⁺ 40-SVA-2 ⁺ 40-SVA-3 ⁺	40/40	1.33 - 2 1.33 - 2.3	24 - 11 46 - 9 66 - 10	1.05 - 0.75 2.05 - 1.25 3 - 1.55	no	17 21 26

The technical data above are valid for water of temperature $T = 20^{\circ}\text{C}$, density $\rho = 1000 \text{ kg}\cdot\text{m}^{-3}$, revolutions $n = 1450 \text{ R.P.M}$, suction head $H_s = 7\text{m}$ and gland packing.

Informative Pump Performance Chart of SVA pumps

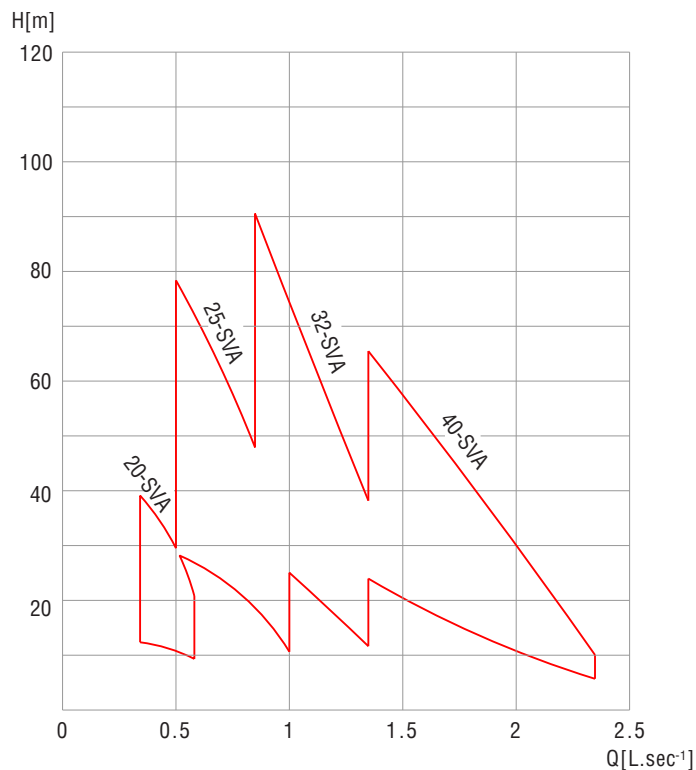

Self Priming Horizontal Pumps SVA

Performance Table of the Pumping Unit type 25, 32-SVA-ME

Pump type	Engine output kW	Flow range l.s ⁻¹	Range of delivery head m	Weight kg
25-SVA-1'	1.1	0.3 - 1.0	29 - 13	41
25-SVA-2'	1.1	0.7 - 1.0	47 - 25	43.5
25-SVA-2'	1.5	0.3 - 1.0	67 - 25	46.5
25-SVA-3'	1.5	0.8 - 1.0	60 - 38	49
25-SVA-3'	2.2	0.3 - 1.0	98 - 38	53
32-SVA-1'	1.1	0.65 - 1.33	37 - 12	42
32-SVA-2'	1.5	1.1 - 1.33	44 - 27	48
32-SVA-2'	2.2	0.6 - 1.33	78 - 27	52
32-SVA-3'	2.2	1.0 - 1.33	70 - 38	55

The technical data above are valid for water of temperature $T = 20^{\circ}\text{C}$, density $\rho = 1000 \text{ kg.m}^{-3}$, revolutions $n = 1450 \text{ R.P.M.}$

Informative Pump Performance Chart of Pumping Unit type 25, 32-SVA-ME

