

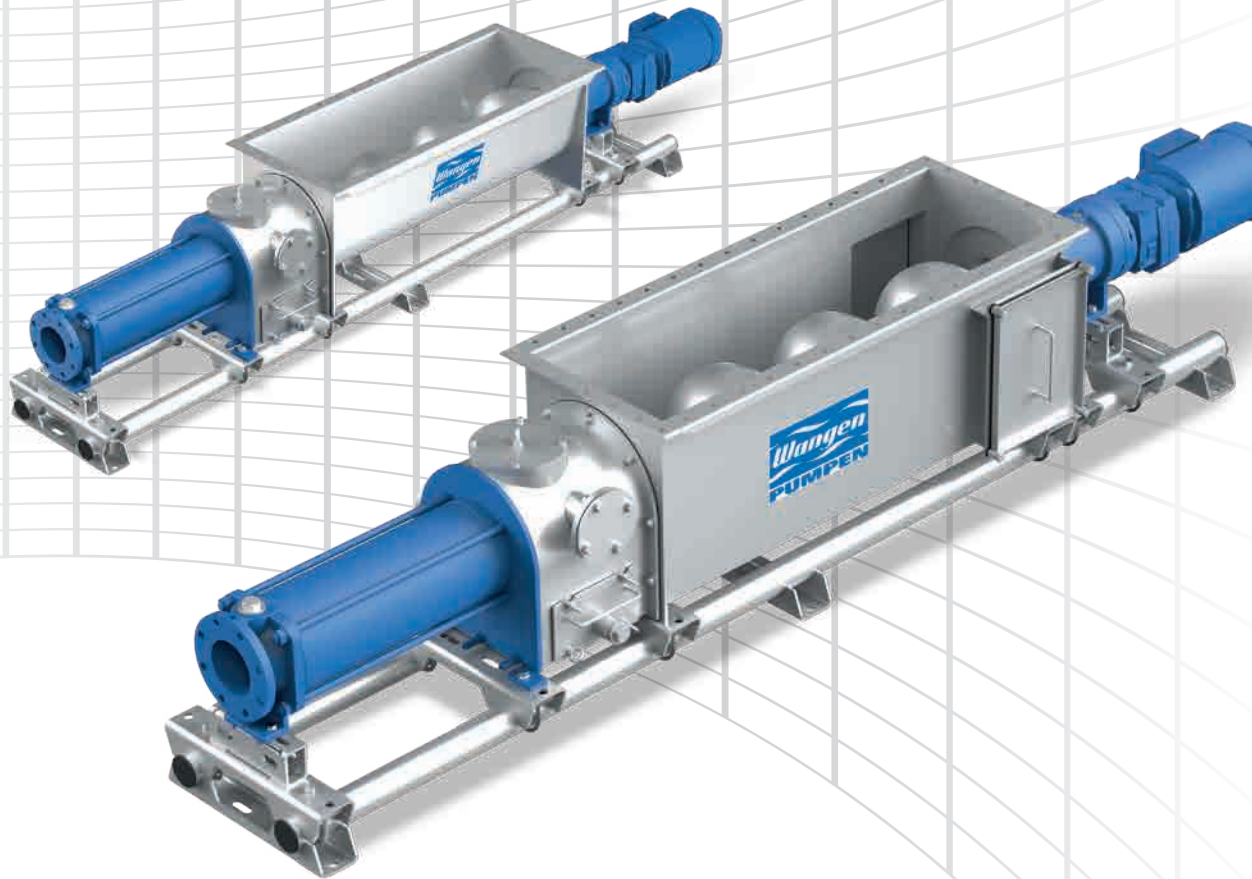

Hopper feed pump
KL-R BIO-MIX



The reliable solution,
specifically for your biogas system

Hopper feed pump

KL-R BIO-MIX

The WANGEN BIO-MIX pumps have been integrated in the process of energy production for years and have been constantly developed and optimized. They are suitable for corn and grass silage, solid and liquid manure, as well as waste and are mixed with fluids in the pump.

The KL-R BIO-MIX is able to cope with long distances and height differences. The wear-protected cardan joints, in conjunction with the worm pre-conveyor are extremely resistant to foreign bodies and contribute to the long lifetime of the pumps.

With the WANGEN KL-R BIO-MIX, we offer the optimum solution for the introduction of solid materials into the fermenter. They are constructed optimally on the basis of the process developed by WANGEN PUMPEN for variable fermenter feeding by way of liquid feeding (repowering). Today, operators are faced by the challenge of carrying out container revisions but still maintaining the operation of the system. The solution for this is the KL-R BIO-MIX.

Technical highlights:

Flowrate up to 150 m³/h

Temperature up to +70°C

Max. differential pressure 12 bar

High solids content of up to 18%

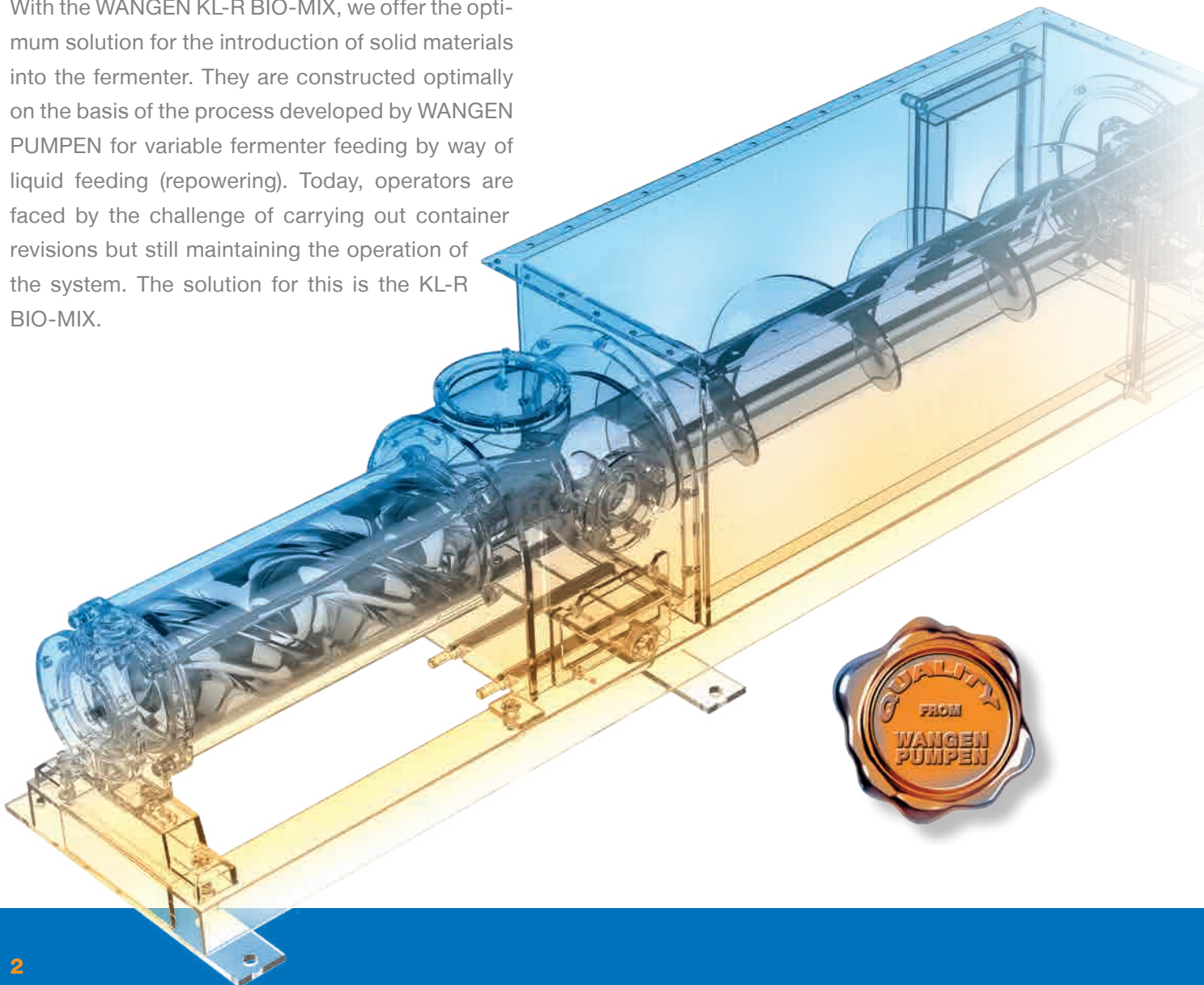

Applications

Conveying Materials

With the hopper pump KL-R BIO-MIX, the following media types are typically conveyed:

- Fruit, such as apples or pears
- Fish waste
- Slaughterhouse waste
- Food waste
- Whole plant silage
- Cereal shreds
- Grass
- Corn silage
- Recirculated products
- Pomace
- Sugar beets
- Liquid manure, also chicken or cow manure



Properties

Construction Characteristics

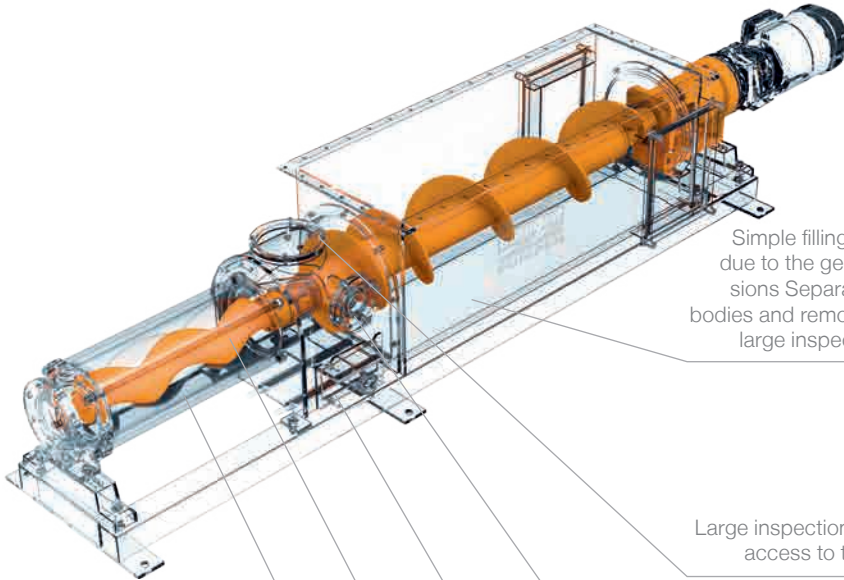

Simple filling of the hopper due to the generous dimensions Separation of foreign bodies and removal of such via large inspection openings

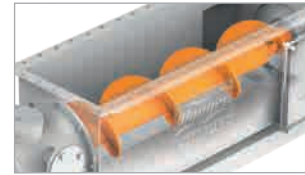

Large inspection flaps for easy access to the tunnel area



Supports right and left for variable connection of fluid feed for mashing



Large inspection flap or cleaning lid with supports for rinsing, cleaning of draining of fluids. Integrated stone collection container



Robust rotor of the highest quality from our own production available in various geometric forms



Conical stator inlet for optimum filling. Stators in various geometries from own manufacturing plant.

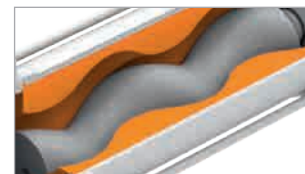

The construction of our pumps shows that they have consistently been designed for performance and reliability. In this way, the stone catching container is extended across the entire hopper length. The removal of impurities is carried out by means of gravity (the substances fall simply into the intended hopper chambers), no additional devices are required. This saves you investment costs, reduces your energy consumption and gives your system high process security.

Properties

We always have the overall process in mind

We see ourselves not just as a supplier of individual components. Our objective is rather to find the best solution for the entire production process. We achieve this by exact observation and analysis of the overall process, not just a part of it. You receive a solution that has been precisely assessed and prepared by the WANGEN PUMPEN specialists.

Whether complex or simple, we guarantee the best possible integration of our machines into your existing or new plant system. You will not only profit from our expertise in mechanical engineering, but also from our many years of experience and the claim to provide our customers with the best solution possible.

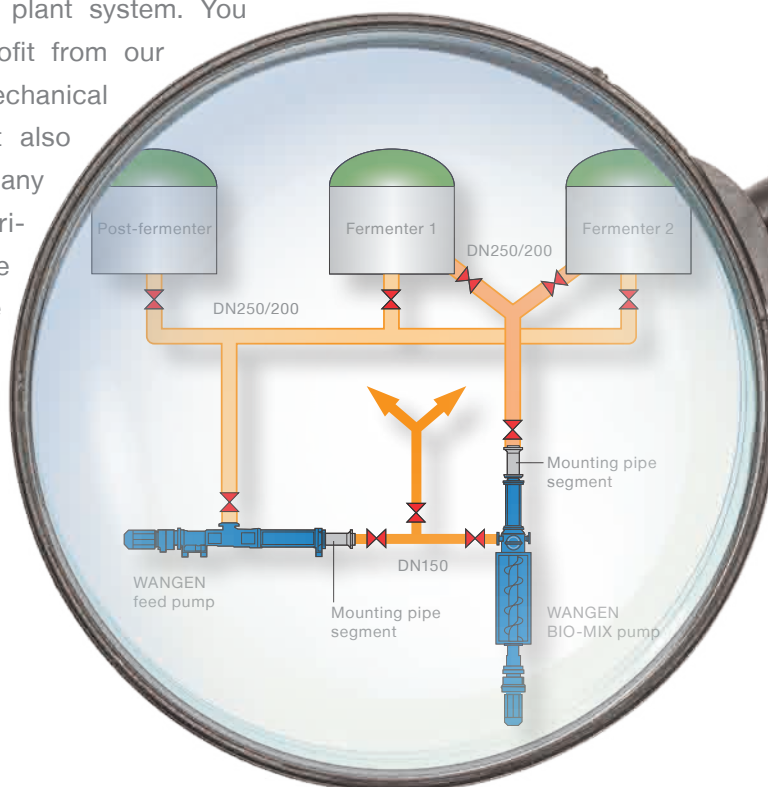

Benefits

Maximum Variability

WANGEN progressing cavity pumps have a modular design. A multitude of standardised construction parts is available for each series and enables each pump to be adapted to meet your specific pumping requirements.

We offer the optimum solution for your application and can provide a maximum efficient pumping solution for your business, regardless of the industry you work in.

Maximum variability means

- Various construction sizes and rotor/ stator sizes mean more than 100 models of the compact pump with a delivery rate ranging from 20 m³/h up to large pumps, which can handle flowrates up to 150 m³/h.
- A large variety of designs and materials is available for casings, rotors, stators, seals, and joints to ensure optimum adaptation to the pumped medium.
- Our broad range of flange connections and drive units assures that the best possible solution for your installation and available space can be found.

We would be happy to assist with developing a customised pump for you.

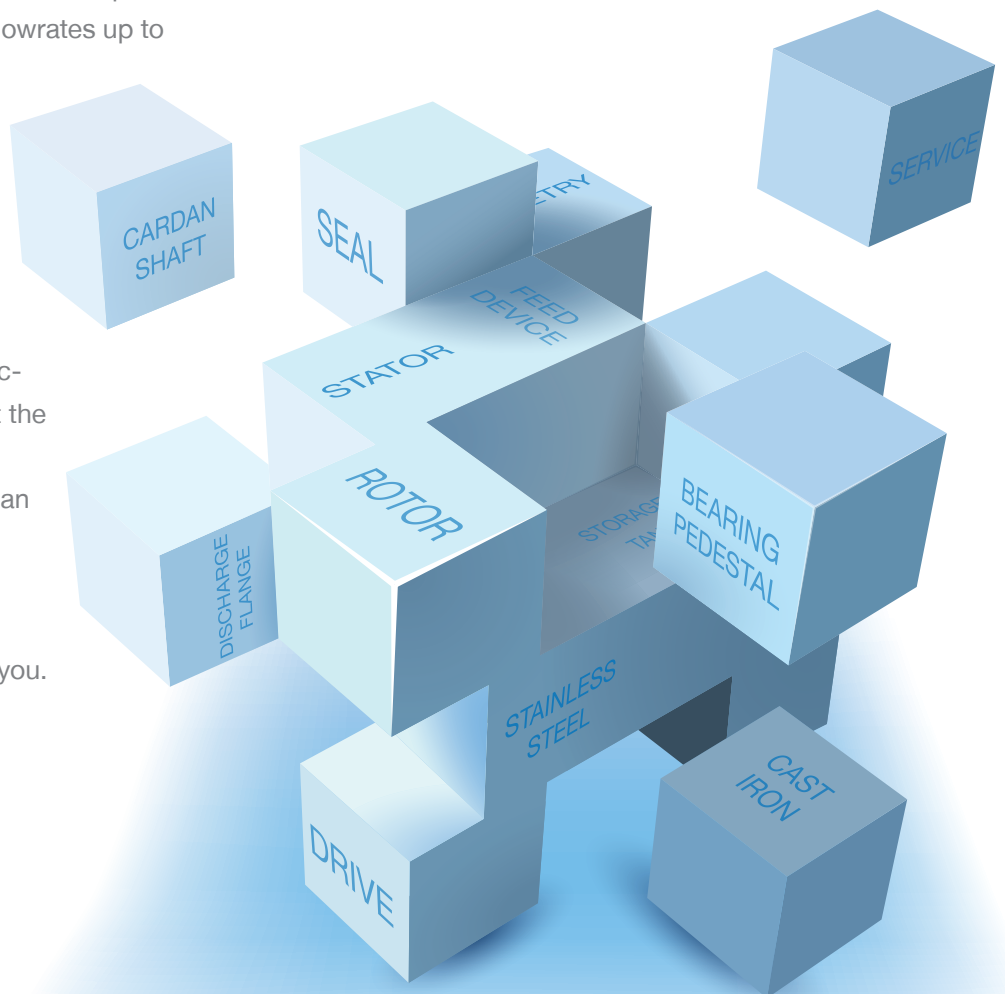

Benefits

Low Life Cycle Costs

When purchasing a pump, we recommend that you carefully consider the operating costs as well as the costs for the initial outlay. Because maintenance costs, production downtimes and energy costs make up a considerable share of the total costs over the life-cycle of a pump.

In this case, a decisive advantage of our philosophy becomes apparent: in order to keep total costs as low as possible over the entire life-cycle of the pump, our approach is to restrict the frequency of maintenance to a minimum. This can be achieved thanks to the robust construction of our pumps, the use of high quality wearing parts and choosing a wear-resistant design for each pump.

Because every breakdown that can be avoided saves you not only the costs for spare parts, but also the costs for maintenance work and production downtimes. In this way, you save on your pocket-book and your nerves.

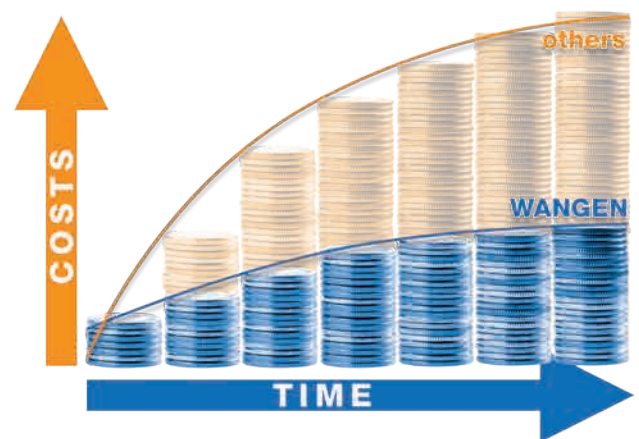

Technical Data

Models and Materials

There is a large selection of standardised construction parts available for the design of your standard suction pump. We provide economical and optimised pumping solutions that are tailor-made for your branch of industry and operating conditions.

- Casing, pressure and suction flange: Stainless steel 1.4301, stainless steel 1.4571
- Joints: stainless steel cardan joints
- Seals: single and double-effect mechanical seals
- Stators: diverse NBR materials, FPM, silicon, EPDM, pressure-stable 'even wall' designs, solid substance stators made of POM
- Rotors and stators in up to 8 pressure classes and available as S-, L- and H geometric forms.
- Drive unit: gearbox motors, hydraulic motors

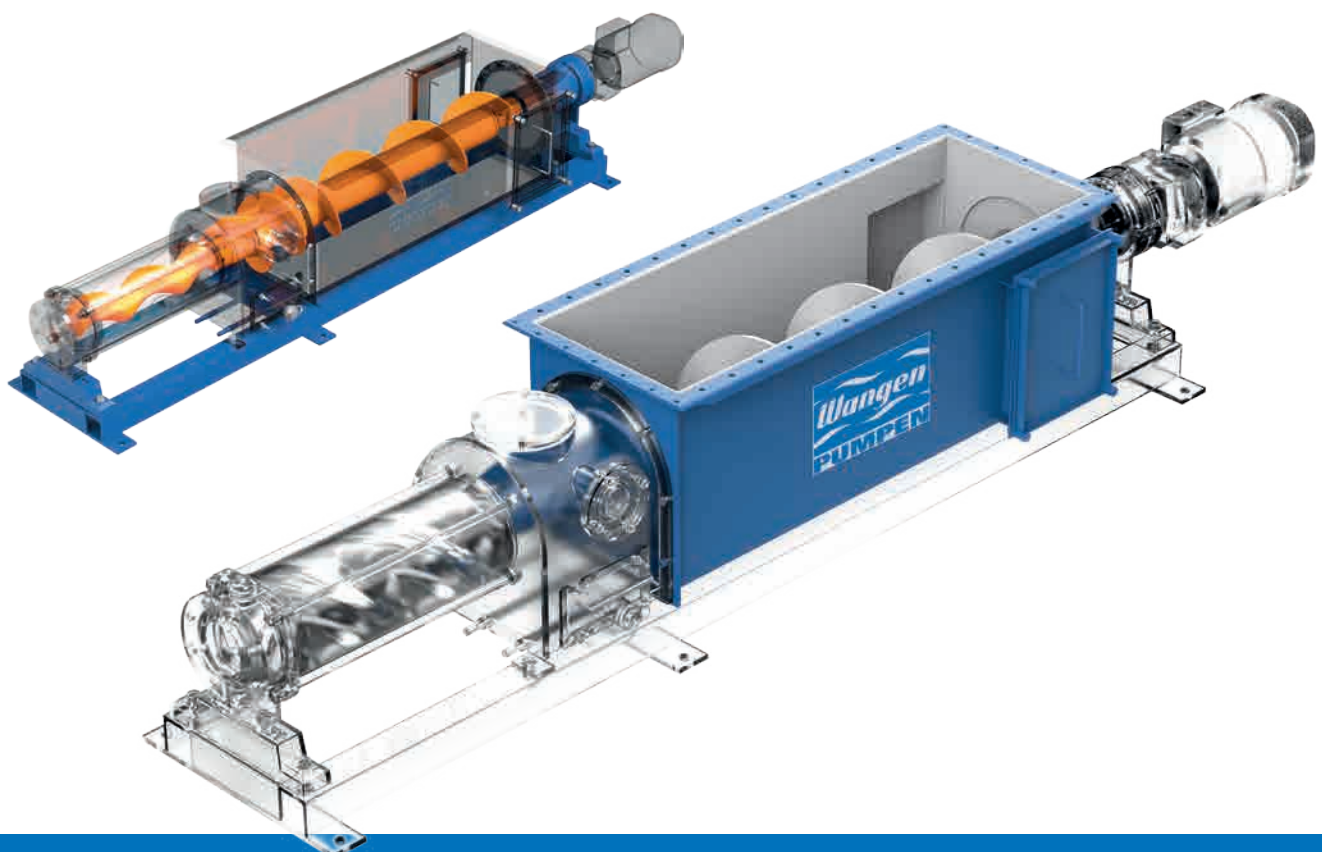

Technical Data

Models and Materials

WANGEN PUMPEN only uses the best materials and components to ensure high operating safety. Due to our many years of experience in this industry, we guarantee a design that meets modern requirements.

The standard version HDS of the KL-R BIO-MIX is supplied with a round hopper and stone collection container after the feed screw.

The HD version is fitted with a square hopper. The advantage of this method of construction is that the entire length of the hopper is used as a stone collector and the foreign bodies collected in the hopper can be removed easily using the large opening located in the rear of the hopper.

Hopper and feed screw are available in both steel and stainless steel. The various rotor and stator sizes enable optimum adaptation to individual requirements.



HDS version
with round hopper
(standard)

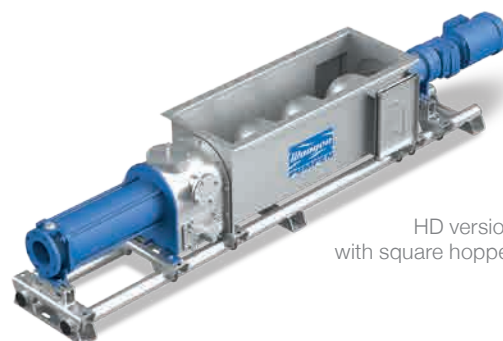

HD version
with square hopper

Spare Parts

By using original spare parts from WANGEN PUMPEN, we guarantee that the performance output of our pumps will be fully restored. With our decades of manufacturing competence, you will be able to profit from our first class quality as a manufacturer and, as a consequence, ensure the long service life of your pump.

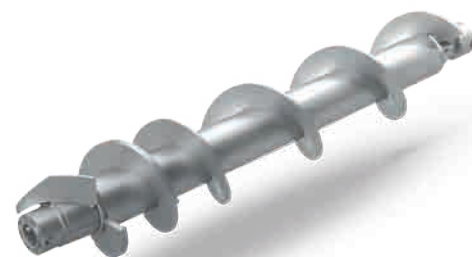
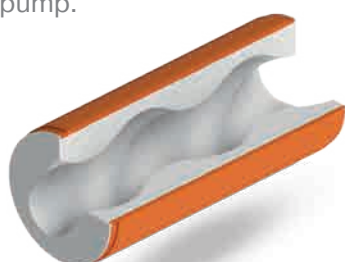

Technical Data

Options and Accessories

We offer a large selection of accessories which are perfectly matched to our product range, providing the ideal complement or adaptation to your individual requirements and allowing you to create your own customized solutions. We would be happy to assist you with customised solutions. .

- Hoppers available in a variety of sizes
- Hoppers in painted steel or stainless steel
- Feed screws in steel or stainless steel
- Optionally with base plate
- Special versions possible for adaptation to existing systems
- and much more

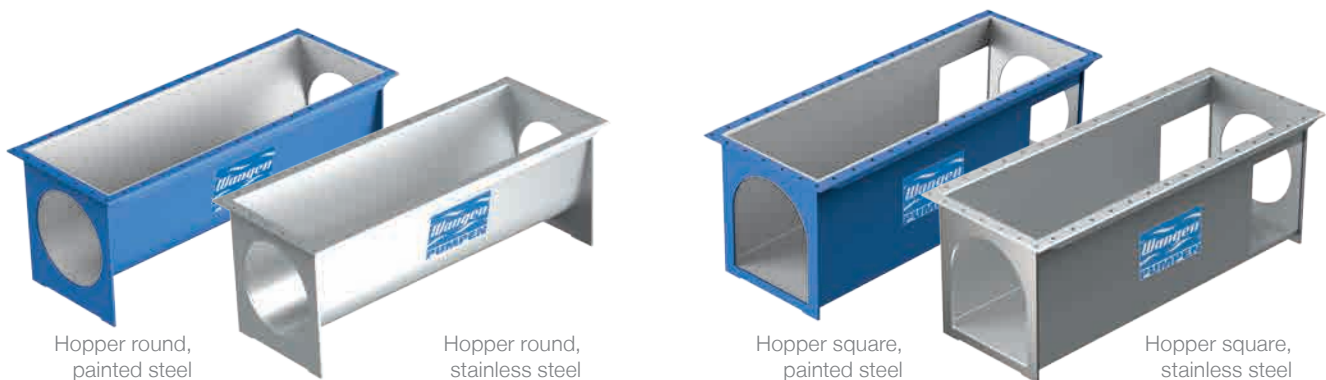

Easy Maintenance

Wangen pumps are user and maintenance friendly. It is easy to switch rotors and shaft seals due to the accessibility of connecting bolts and the cartridge construction of the sealing package. This makes it easier for you to carry out the necessary maintenance yourself.



Technical Data

Performance Data KL-R BIO-MIX

Pump size	Maximum free ball passage (mm)	Max. flowrate (m ³ /h) at 100 min ⁻¹	Maximum differential pressure (bar)
50	95	20	9
65	112	40	12
80	121	85	12
100	150	150	12



Large inspection and cleaning openings

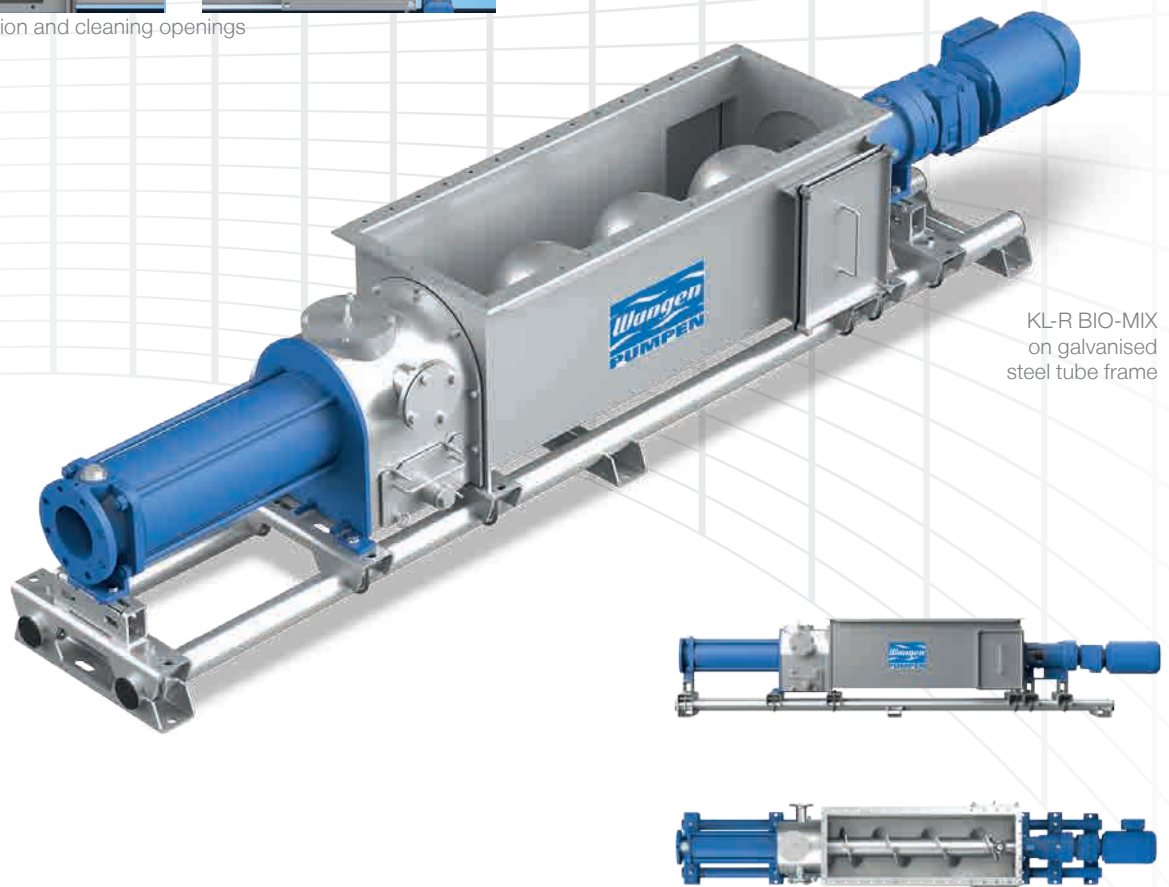

KL-R BIO-MIX
on galvanised
steel tube frame



Online Newsletter

Subscribe now and be informed!

Go to www.wangen.com



Tested quality

WANGEN PUMPEN Quality management is certified to ISO 9001:2008.



Certified sustainability

The WANGEN PUMPEN environmental management is certified according to ISO 14001:2004.



Your contact:

Pumpenfabrik Wangen GmbH

Simoniusstrasse 17
88239 Wangen im Allg.
Germany
www.wangen.com

Service Hotline: +49 7522 997-997
Spare parts: +49 7522 997-896