

# K SEMI ROTARY HAND WING PUMPS

## APPLICATION

- semi rotary hand wing pumps are designed for pumping clean liquids without mechanical impurities up to 80 °C.
- semi rotary hand wing pumps K-N
  - for pumping drinking and process water
  - suitable for flooding of pump suction pipe
  - not intended for pumping flammable liquids
- semi rotary hand wing pumps K-B + K-BS
  - for pumping flammable liquids (such as gasoline, diesel, kerosene and other fuels, paraffin, alcohol, light chemical solutions, eatable oils etc.) in hazardous areas zone 1 and 2 (according to EN 60079-10) above  $\rho = 770 \text{ kg / m}^3$ , viscosity of  $0.7 \text{ mm}^2 / \text{s}$  and 2 (acc. to ČSN EN 60079-10) above  $\rho = 770 \text{ kg/m}^3$ , viscosity above  $0.7 \text{ mm}^2 / \text{s}$ .
  - pumping of ether and carbon disulphide is prohibited!
  - installed pump must be always electrostatically grounded, if electrostatic grounding is not ensured by other means (for example through the suction or discharge pipes, etc.) must be grounding connected to the connecting screws of cover and body between two lock washers
  - for pumping jet fuel is intended all-bronze design, K1-BB
  - can be used for pumping water

## TYPE IDENTIFICATION

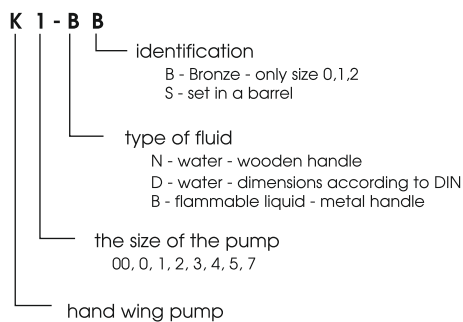

## CONSTRUCTION

- **K**
  - semi rotary hand wing pumps K, K-B, K-D, K-BB - consists of the body, cover, wing, suction divider, 4x butterfly valve, shaft and handle, the shaft operated by hand swings precisely machined wing that is moving in the pump body and on the suction side is set fixed suction divider
  - wing and suction divider split the inner space into four parts
  - in the wing and suction divider are cut butterfly valves, allowing air intake and discharge at wing movement - so-called double - acting operation - half wing sucks and the other fluid displaces
  - the body is closed with cover, through which passes the shaft with handle, washer and nut, shaft sealing in the cover is made by soft (cord) packing (asbestos-free) - pushed by matrix
  - the pump has two feet for mounting on a vertical wall, bracket or other structure, for its connection are used flanges with threaded counter-flanges
  - the design and material of the pumps KB, K-BB provides their electrostatic conductivity and must be grounded
- **K-BS**
  - hand pump sets consist of:
    - from modified wing design pumps KB (without mounting feet and without suction and discharge flanges) and must be grounded
    - from suction rank formed by suction tube L and barrel plug in cylinder design
    - from the discharge rank with the discharge tube
  - suction rank:
    - is composed of galvanized pipe and connecting barrel plug- a cylindrical plugs with thread G2 "that allows installation on barrels and for setting required immersion in a barrel
    - plug on the suction pipe is secured by setscrew
  - discharge rank:
    - consists of the discharge tube and fluid outlet is directly at the pump

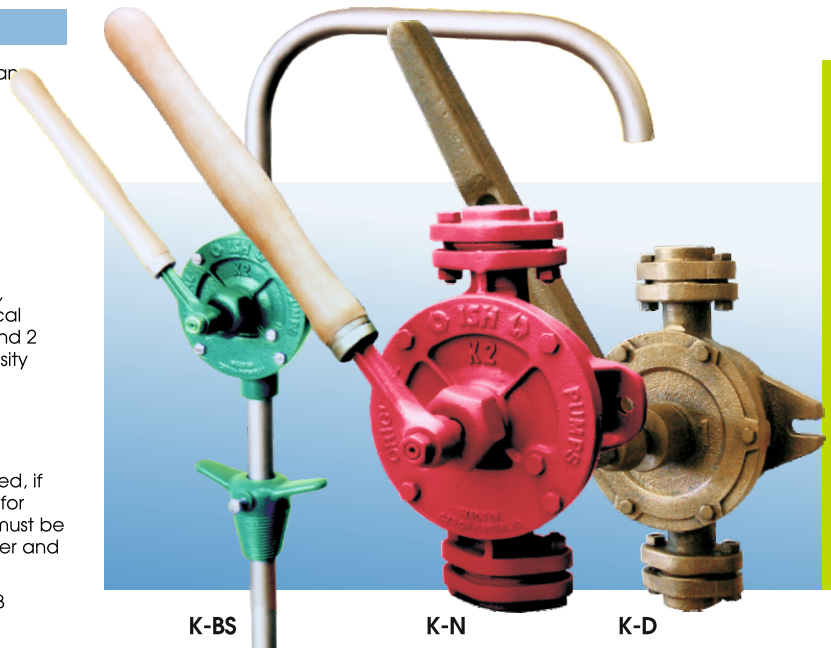

K-BS

K-N

K-D

## Pump components

- |                       |                  |                         |
|-----------------------|------------------|-------------------------|
| ■ 1 - body            | ■ 6 - valves     | ■ 11 - washer           |
| ■ 2 - cover           | ■ 7 - handle     | ■ 12 - counter-flange   |
| ■ 3 - packing nut     | ■ 8 - seal       | ■ 13 - flange fasteners |
| ■ 4 - wing and shaft  | ■ 9 - ring seal  | ■ 14 - cover fasteners  |
| ■ 5 - suction divider | ■ 10 - shaft nut | ■ 15 - gaskets          |

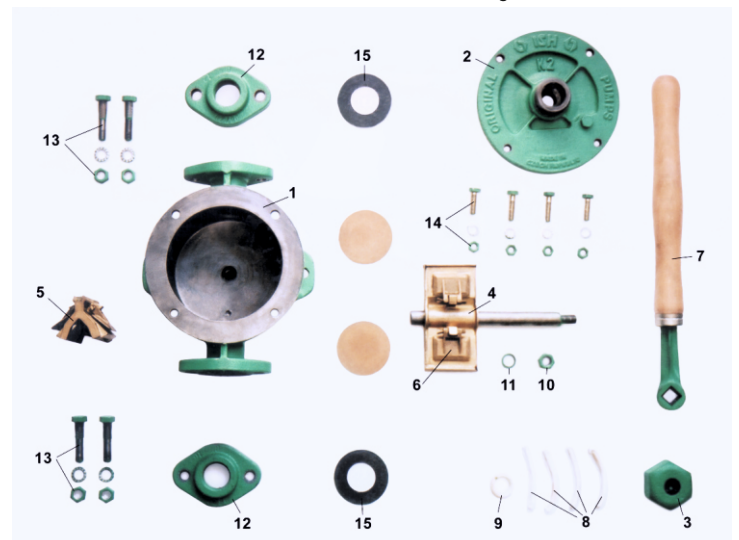

Size		K 0	K 1	K 2	K 3	K 4	K 5
DN	mm	15	20	25	32	32	40
G	inches	1/2	3/4	1	1 1/4	1 1/4	1 1/2
A	mm	130	130	149	169	185	195
B	mm	52	50	55	57	72	73
F	mm	16	20	18	24	28	31
I	mm	14	13	12	16	16	17
K	mm	130	150	170	200	220	240
L	mm	175	205	230	275	295	320
M	mm	160	180	194	240	255	275
O	mm	13	13	13	13	13	13
P	mm	300	320	360	450	500	600
combustibles - S	mm	167	167	195	237	253	263
H	mm	35	30	37	33	40	37
U	mm	25	25	27	30	32	35
min. flow	l.min <sup>-1</sup>	10,5	16,5	24	30,5	45	53,5
max. suction height	m	7	7	7	7	7	7
max. delivery head	m	25	25	25	22	22	20
Number of double strokes	-	65	60	55	50	50	45
weight	kg	5,1	6,1	8,8	11,5	12,6	16,0

Size		K 00	K 0	K 1	K 2	K 3	K 4	K 5	K 7
DN	mm	10	15	20	25	32	32	40	50
G	inches	3/8	1/2	3/4	1	1 1/4	1 1/4	1 1/2	2
A	mm	136	141	141	164	177	194	208	222
B	mm	50	52	50	55	58	74	73	86
F	mm	20	22	20	18	25	30	30	34
I	mm	10	12	12	12	15	15	16	15
K	mm	98	125	145	165	175	195	220	290
L	mm	110	175	205	230	235	260	290	360
M	mm	120	160	180	200	205	235	280	340
O	mm	7	12	12	12	12	13	13	15
P	mm	230	300	300	360	550	550	600	600
S	mm	112	166	166	195	237	254	262	268
U	mm	26	25	30	32	30	32	40	46
min. flow	l.min <sup>-1</sup>	9	11	18	30	33	50	58	90
Max. suction height	m	7	7	7	7	7	7	7	7
max. discharge head	m	25	25	25	25	22	22	20	15
Number of double strokes	-	80	65	60	55	50	50	45	40
weight	kg	3,2	6,0	7,0	9,0	12,0	14,5	18,0	31,6

Size		K -BS	K 0	K 1	K 2
DN	mm	all	15	20	25
G	inches	all	1/2	3/4	1
D	mm	all	135	150	170
A	mm	all	130	130	149
B	mm	all	50	50	57
C	mm	all	175	205	230
E II	mm	II ___	430	460	460
L II	mm	II ___	295	292	311
L s	mm	_ S _	870	880	893
L L	mm	_ L _	1170	1180	1193
Pw	mm	_ _ W _	320	360	450
Pc	mm	_ _ C _	300	320	360
S	mm	_ _ C _	167	167	195
min. flow	l.min <sup>-1</sup>	all	10,5	16,5	24
max. suction height	m	all	7	7	7
max. discharge head	m	all	25	25	25
number of double strokes	-	all	65	60	55
weight	kg	II _ W _	7,7	9,5	13
weight	kg	II _ C _	8,7	10,5	14

- dimensions are in millimeters and are informative
- dimensions are in millimeters and are informative 20 °C
- flow rate Q is valid for the specified number of double strokes and geodetic suction and discharge head and ZVG ZSG = 1 m. At maximum geodetic suction and discharge head ZSG ZVG is not valid the Q mentioned in the table
- max. ZSG geodetic suction height mentioned in the table reaches watered pump with basket, unwatered pump reaches geodetic suction height ZSG = 2 m

### BASIC DIMENSIONS

