

hydroo[®]

TDROO SERIES

TF/TX

**Vertical in-line
circulation pump
50-60Hz**





PRESENTATION

Hydroo Pump Industries SL is an enterprise specialised in the research, development and large-scale production of Stainless Steel centrifugal pumps. We have a vertical integration of the production processes, standing out stamping, welding and motor wiring in 6 value centers and production units. All of them with a high performance management on pump engineering and production quality.

HYDROO has set up a wide range of pumping solutions for many applications as building services, industry, irrigation and industrial process. Customers enjoy of the highest performance in booster sets and pressurization, fire-fighting sets, pumping of underground water, HVAC, drainage and sewage, utilities, desalination and OEM integrations. Versions in 50 Hz and 60 Hz are available, as well as any modification on materials, on request.

Global water challenges require excellence in pumping technologies and close cooperation between pump designers,

manufacturers and pump engineers. In order to better meet the customers' needs and requirements our company is facing an expansion of its operations worldwide, providing timely and effective services in more than 30 countries. With tight relationships in many regions, we're proud to introduce a new regional value center for Europe. We are based near Barcelona at the Girona industrial area. **Hydroo** is a trademark to forge excellent and successful business relationships with our value customers by means of an operative assembling unit and an application engineering unit. **HYDROO** trademark wants to symbolize the firm commitment for a high level service to our value partners.

At Hydroo we bet on a high level service to our value pump partners.

TDROO

Vertical in-line circulation pump

Applications

Cooling water
Water supply/distribution
Drainage
Irrigation
General industrial services
Boosting

Description

Vertical in-line circulation pumps. Standard totally enclosed, fan cooled, insulation class F, IP 55 motors. Single phase motors up to 2,2 kW.

Standard versions are suitable for smart pumping of clean water with a temperature range between -15°C to 110°C, on request.

F: Cast Iron Impeller
X: SS304 Impeller

Performance range

Capacity: Q up to 750 m³/h

Head: H up to 90 m

Temperature: T up to 110 °C

Speed: 2900/1450 rpm
3500/1750 rpm

Power: P up to 132 kW

Standard material

Casing: Cast iron
Shaft: Stainless steel
Impeller: Cast iron
or stainless steel 304.



Introduction

TDROO Series are single stage in-line centrifugal pumps, equipped with standard motor and mechanical seal. Comparing with other pumps in similar structure, these pumps are less accessible to the impurity in the liquid.

The pump is designed to be pulled out from the top when disassemble. It can be repaired without affecting the pipelines.

The mechanical seal for TF, TX200 and above is cartridge mechanical seal. Motor needn't to be disassembled when replace mechanical seal.

TF, TX125—TF, TX150 products have two structures, one is easy maintenance structure, using a cartridge mechanical seal. And another is expansion shaft structure.

Curve conditions

Following conditions are suitable for the performance curves shown above.

1. All curves are based on the measured value of motor 3 X380V, 50Hz: under the constant speed of 2900rpm, 1450rpm or 1480rpm; 60Hz: under the constant speed of 3500rpm or 1750rpm;

2. Curve tolerance in conformity with ISO9906: 2012,3B.

3. Measurement is done with 20 °C air-free water, without impurities.

4. The operation of pump shall refer to the performance region indicated by the thickened curve to prevent overheating due to too small flow rate or overload of motor due to too large flow rate.

5. If the thickness and density of the pumped liquid is different from water, the motor power should be adjusted.

Definition of model

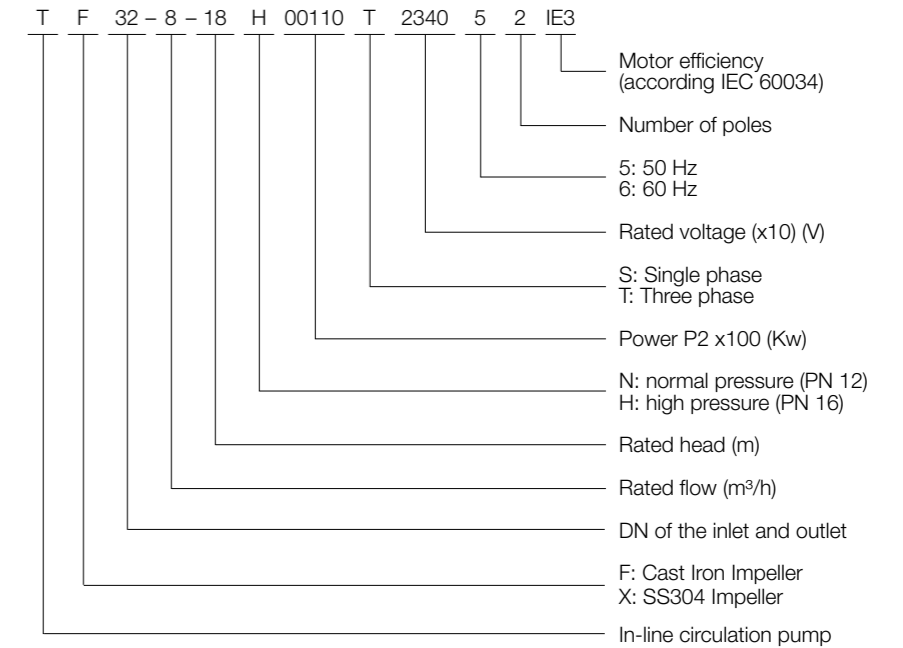

Performance scoop

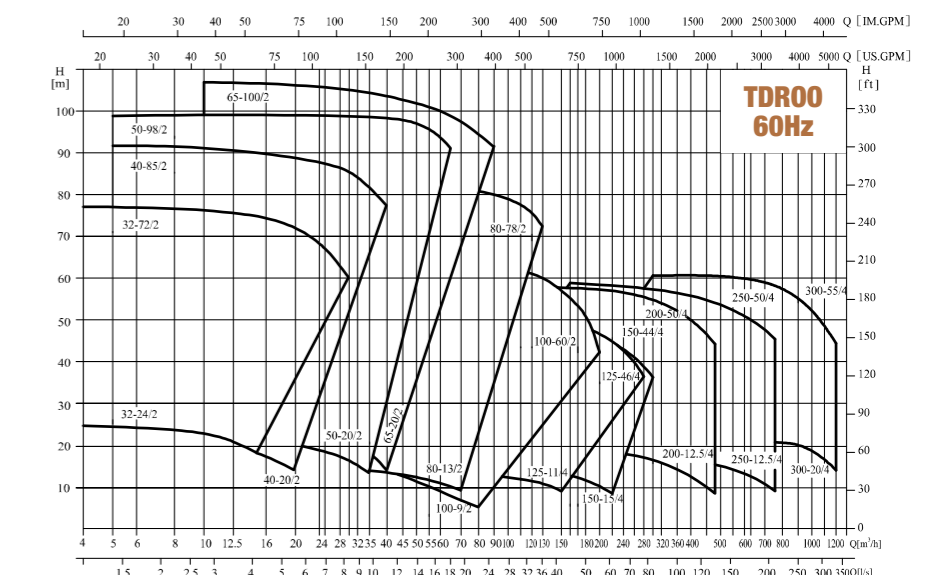
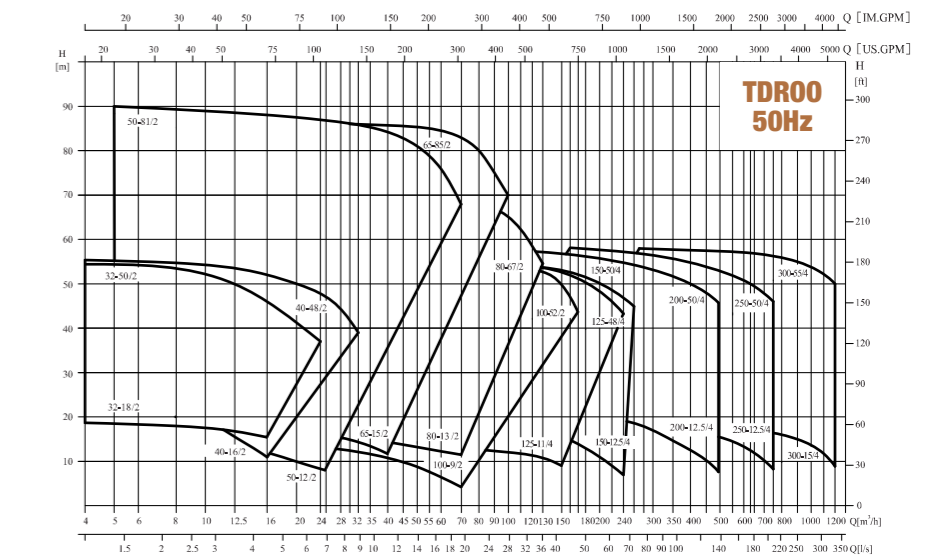

N°	Model	Q (m³/h)	H (m)	n (r/min)	Standard voltage (V)	
					1x220V	3x380V
					P2 (kW)	P2 (kW)
1	TF, TX 32-8-18	8	18	2900	1.1	1.1
2	TF, TX 32-12.5-21	12.5	21		1.5	1.5
3	TF, TX 32-12.5-26	12.5	26		2.2	2.2
4	TF, TX 32-12.5-33	12.5	33			3
5	TF, TX 32-12.5-40	12.5	40			4
6	TF, TX 32-12.5-50	12.5	50			5.5
7	TF, TX 40-12.5-16	12.5	16		1.1	1.1
8	TF, TX 40-12.5-21	12.5	21		1.5	1.5
9	TF, TX 40-20-20	20	20		2.2	2.2
10	TF, TX 40-18-26	20	26			3
11	TF, TX 40-25-30	25	30			4
12	TF, TX 40-25-36	25	36			5.5
13	TF, TX 40-25-48	25	48			7.5
14	TF, TX 50-12.5-32	12.5	32			3
15	TF, TX 50-12.5-39	12.5	39			4
16	TF, TX 50-12.5-49	12.5	49			5.5
17	TF, TX 50-12.5-59	12.5	59			7.5
18	TF, TX 50-12.5-80	12.5	80			11
19	TF, TX 50-16-12	16	12		1.1	1.1
20	TF, TX 50-20-15	20	15		1.5	1.5
21	TF, TX 50-25-18	25	18		2.2	2.2
22	TF, TX 50-25-24	25	24			3
23	TF, TX 50-30-28	30	28			4
24	TF, TX 50-30-35	30	35			5.5
25	TF, TX 50-35-40	35	40			7.5
26	TF, TX 50-40-50	40	50			11
27	TF, TX 50-50-60	50	60			15
28	TF, TX 50-50-70	50	70			18.5
29	TF, TX 50-50-81	50	81			22
30	TF, TX 65-25-37	25	37			5.5
31	TF, TX 65-25-48	25	48			7.5
32	TF, TX 65-30-15	30	15		2.2	2.2
33	TF, TX 65-30-20	30	20			3
34	TF, TX 65-40-22	40	22			4
35	TF, TX 65-40-30	40	30			5.5
36	TF, TX 65-50-34	50	34			7.5
37	TF, TX 65-50-41	50	41			11
38	TF, TX 65-50-51	50	51			15
39	TF, TX 65-50-61	50	61			18.5
40	TF, TX 65-50-68	50	68			22
41	TF, TX 65-50-85	50	85			30
42	TF, TX 80-50-41	50	41			11
43	TF, TX 80-50-48	50	48			15
44	TF, TX 80-50-13	50	13			3
45	TF, TX 80-50-18	50	18			4
46	TF, TX 80-50-23	50	23			5.5
47	TF, TX 80-50-29	50	29			7.5
48	TF, TX 80-70-32	70	32			11
49	TF, TX 80-80-38	80	38			15
50	TF, TX 80-80-47	80	47			18.5
51	TF, TX 80-80-54	80	54			22
52	TF, TX 80-80-67	80	67			30
53	TF, TX 100-50-9	50	9		2.2	2.2
54	TF, TX 100-60-15	60	15			4
55	TF, TX 100-80-17	80	17			5.5
56	TF, TX 100-78-22	80	22			7.5

N°	Model	Q (m³/h)	H (m)	n (r/min)	Standard voltage (V)	
					1x220V	3x380V
					P2 (kW)	P2 (kW)
57	TF, TX 100-100-27	100	27	2900		11
58	TF, TX 100-100-33	100	33			15
59	TF, TX 100-100-40	100	40			18.5
60	TF, TX 100-100-48	100	48			22
61	TF, TX 100-130-52	130	52			30
62	TF, TX 125-120-11	120	11		1450	
63	TF, TX 125-120-14	120	14			7.5
64	TF, TX 125-140-19	140	19			11
65	TF, TX 125-160-22	160	22			15
66	TF, TX 125-160-28	160	28			18.5
67	TF, TX 125-160-32	160	32			22
68	TF, TX 125-160-40	160	40		30	
69	TF, TX 125-160-48	160	48		37	
70	TF, TX 150-200-12.5	200	12.5		11	
71	TF, TX 150-200-17	200	17		15	
72	TF, TX 150-200-22	200	22		18.5	
73	TF, TX 150-200-25	200	25		22	
74	TF, TX 150-200-33	200	33		30	
75	TF, TX 150-200-40	200	40		37	
76	TF, TX 150-200-50	200	50		45	
77	TF, TX 200-300-16	300	16		18.5	
78	TF, TX 200-300-19	300	19		22	
79	TF, TX 200-300-24	300	24		30	
80	TF, TX 200-300-31	300	31		37	
81	TF, TX 200-300-36	300	36		45	
82	TF, TX 200-300-47	300	47		55	
83	TF, TX 200-300-53	300	53		75	
84	TF, TX 200-400-12.5	400	12.5		22	
85	TF, TX 200-400-20	400	20		30	
86	TF, TX 200-400-23	400	23		37	
87	TF, TX 200-400-27	400	27		45	
88	TF, TX 200-400-32	400	32	1480		55
89	TF, TX 200-400-43	400	43			75
90	TF, TX 200-400-50	400	50			90
91	TF, TX 250-500-16	500	16			30
92	TF, TX 250-500-19	500	19			37
93	TF, TX 250-500-22	500	22			45
94	TF, TX 250-500-29	500	29			55
95	TF, TX 250-500-36	500	36			75
96	TF, TX 250-500-47	500	47			90
97	TF, TX 250-500-56	500	56			110
98	TF, TX 250-630-12.5	630	12.5			30
99	TF, TX 250-630-14	630	14			37
100	TF, TX 250-630-17	630	17			45
101	TF, TX 250-630-20	630	20			55
102	TF, TX 250-630-26	630	26			75
103	TF, TX 250-630-32	630	32			90
104	TF, TX 250-630-40	630	40			110
105	TF, TX 250-630-50	630	50			132
106	TF, TX 300-900-15	900	15			55
107	TF, TX 300-900-20	900	20			75
108	TF, TX 300-900-25	900	25			90
109	TF, TX 300-900-30	900	30			110
110	TF, TX 300-900-35	900	35			132
111	TF, TX 300-900-44	900	44			160
112	TF, TX 300-900-55	900	55		200	

N°	Model	Q (m³/h)	H (m)	n (r/min)	Standard voltage (V)	
					1x220V	3x380V
					P2 (kW)	P2 (kW)
1	TF, TX 32-7-24	7	24	3500	1.5	1.5
2	TF, TX 32-10-27	10	27		2.2	2.2
3	TF, TX 32-15-30	15	30			3
4	TF, TX 32-15-38	15	38			4
5	TF, TX 32-15-46	15	46			5.5
6	TF, TX 32-20-57	20	57			7.5
7	TF, TX 32-20-72	20	72			11
8	TF, TX 40-12-20	12	20			1.5
9	TF, TX 40-15-24	15	24			2.2
10	TF, TX 40-15-28	15	28			
11	TF, TX 40-20-32	20	32			3
12	TF, TX 40-25-35	25	35			4
13	TF, TX 40-25-42	25	42			5.5
14	TF, TX 40-25-65	25	65			7.5
15	TF, TX 40-25-76	25	76			11
16	TF, TX 40-30-85	30	85			15
17	TF, TX 50-20-20	20	20			18.5
18	TF, TX 50-20-27	20	27			2.2
19	TF, TX 50-20-34	20	34			2.2
20	TF, TX 50-20-40	20	40			3
21	TF, TX 50-30-42	30	42			4
22	TF, TX 50-35-51	35	51			5.5
23	TF, TX 50-45-62	45	62			7.5
24	TF, TX 50-45-72	45	72			11
25	TF, TX 50-45-84	45	84			15
26	TF, TX 50-50-98	50	98			18.5
27	TF, TX 65-30-20	30	20			22
28	TF, TX 65-30-25	30	25			30
29	TF, TX 65-30-32	30	32			3
30	TF, TX 65-35-38	35	38			4
31	TF, TX 65-35-46	35	46		5.5	
32	TF, TX 65-35-55	35	55		7.5	
33	TF, TX 65-50-60	50	60		11	
34	TF, TX 65-50-73	50	73		15	
35	TF, TX 65-60-85	60	85		18.5	
36	TF, TX 65-60-100	60	100		22	
37	TF, TX 80-50-12	50	12		30	
38	TF, TX 80-50-17	50	17		37	
39	TF, TX 80-60-20	60	20		3	
40	TF, TX 80-60-26	60	26		4	
41	TF, TX 80-80-30	80	30		5.5	
42	TF, TX 80-80-38	80	38		7.5	
43	TF, TX 80-80-47	80	47		11	
44	TF, TX 80-80-52	80	52		15	
45	TF, TX 80-80-70	80	70		18.5	
46	TF, TX 80-80-81	80	81		22	
47	TF, TX 100-50-11	50	11		30	
48	TF, TX 100-60-15	60	15		37	
49	TF, TX 100-80-17	80	17		3	
50	TF, TX 100-80-22	80	22		4	
51	TF, TX 100-100-25	100	25		5.5	
52	TF, TX 100-100-32	100	32		7.5	
53	TF, TX 100-120-34	120	34		11	
54	TF, TX 100-120-38	120	38		15	
55	TF, TX 100-130-52	130	52		18.5	
56	TF, TX 100-130-60	130	60		22	
57	TF, TX 125-120-11	120	11		30	
58	TF, TX 125-120-14	120	14		37	
59	TF, TX 125-120-20	120	20		3	

N°	Model	Q (m³/h)	H (m)	n (r/min)	Standard voltage (V)	
					1x220V	3x380V
					P2 (kW)	P2 (kW)
60	TF, TX 125-120-24	120	24	1750		15
61	TF, TX 125-140-28	140	28			18.5
62	TF, TX 125-150-32	150	32			22
63	TF, TX 125-150-38	150	38			30
64	TF, TX 125-180-40	180	40			37
65	TF, TX 125-180-46	180	46			45
66	TF, TX 150-160-15	160	15			11
67	TF, TX 150-180-18	180	18			15
68	TF, TX 150-200-20	200	20			18.5
69	TF, TX 150-200-24	200	24			22
70	TF, TX 150-200-32	200	32			30
71	TF, TX 150-200-36	200	36			37
72	TF, TX 150-200-44	200	44			45
73	TF, TX 200-400-12.5	400	12.5			22
74	TF, TX 200-400-20	400	20			30
75	TF, TX 200-400-23	400	23			37
76	TF, TX 200-400-27	400	27			45
77	TF, TX 200-400-32	400	32			55
78	TF, TX 200-400-43	400	43			75
79	TF, TX 200-400-50	400	50			90
80	TF, TX 250-630-14	630	14			37
81	TF, TX 250-630-17	630	17			45
82	TF, TX 250-630-20	630	20			55
83	TF, TX 250-630-26	630	26			75
84	TF, TX 250-630-32	630	32			90
85	TF, TX 250-630-40	630	40			110
86	TF, TX 250-630-50	630	50			132
87	TF, TX 300-900-20	900	20			75
88	TF, TX 300-900-25	900	25			90
89	TF, TX 300-900-30	900	30			110
90	TF, TX 300-900-35	900	35		132	
91	TF, TX 300-900-44	900	44		160	
92	TF, TX 300-900-55	900	55		200	

Minimum inlet pressure NPSH

In case that the pressure in pump is lower than the steam pressure used to convey liquid, the cavitations will occur. To avoid cavitations, a minimum pressure at the inlet side of the pump shall be guaranteed. The maximum suction can be calculated with following formula:
 $H = Pb \times 10.2 - NPSH - H_f - H_v - H_s$
 H— Maximum suction head (m)

Pb— Atmosphere pressure (bar)
 In a closed system, Pb means system pressure (bar)
 NPSH— Net positive suction head (m)
 It can be read from the point of Max. flow rate shown on NPSH curve.
 Hf— Pipeline loss at the inlet (m)
 It is in accordance with pipeline possible Max. flow.
 Hv— Steam pressure (m)
 It depends on liquid temperature and steam pressure value.
 Hs— Safety margin (m)
 Minimum 0.5m delivery head.

If the calculated result H is negative, the pump may run under the Max. suction head H. In case the calculated result H is negative, a delivery head of Min. inlet pressure is necessary.

Note: Normally, the above calculation will not be done. H is calculated in the following conditions:

1. The liquid temperature is comparatively higher.
2. Liquid flow exceeds rated value.
3. Suction head is comparatively large or inlet pipeline long.
4. System pressure is too low.
5. Bad inlet condition.

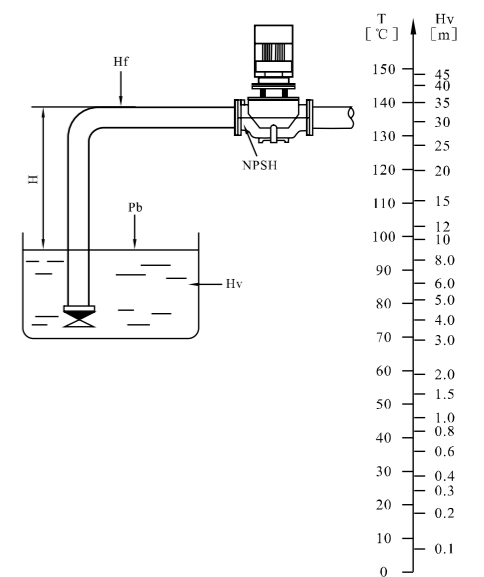

Applications

The pumped liquid is clean, thin, non-corrosive, non-flammable, and non-explosive liquid which shall not contain any solid grain and fibre that might damage the pump mechanically or chemically.

The detailed requirements on the liquid is in Table 3. If the liquid viscosity or density is beyond the required level, the performance curves will descend and energy consumption will be increased.

Liquid temperature: -15 °C ~ 110 °C
Max. Working pressure: Normal type: PN12 bar; special type: PN 16 bar.

	Liquid	Max. temperature	Liquid requirement	Application
Water	Groundwater	< 90 °C		TD pumps are applicable for urban water supply, industrial water, cooling system, and cold & hot water for regional heat supply system: 1) main circulation pump 2) mixed circuit pump 3) boiler mixed-flow pump 4) gas-fired freezer pump 5) filter pump 6) constant pressure system pump 7) urban hot water circulation
	Boiler feed water	<110 °C		
	District feed water	<110 °C		
	Condensate	<90 °C		
	Softened water	-15 °C ~ 110 °C		
	Alkalescent water		Weak alkalescence	
Cooling and cutting lubricant		Additive and little impurity may damage the shaft seal		
Coolants	Hydrocarbon based antifreeze	<50 °C	Little rime may damage the shaft seal	TD pumps can be used in chemical industry, pharmaceutical industry, food processing and so on. 1) liquid feeding 2) system pressure boosting 3) mixed circuit circulation pump
	Alcoholised compound	<50 °C 50%		
	30% brine (Nacl, Cacl2 solution, etc)	<50 °C	Little rime may damage the shaft seal	
Organic solvents	Isopropyl alcohol	≤60 °C	Flammable liquid	
	Propyl alcohol	≤60 °C		
Oxidants	Hydrogen peroxide	≤60 °C 20%		

Installation requirements

Some detailed requirement of installation is as below, The concrete request is as following:

- If the system pipeline can support the pumps, pumps with 2.2kW motorpower(including 2.2kW) can be hung in line; if the system pipeline cannot support the pumps or the pump motor power is higher than 2.2kW, the pumps must be installed in brackets or base.
- Pumps with motor power lower than 2.2kW(including 2.2kW) can be installed horizontally or vertically to the pipeline. Pumps with motor power higher than 2.2kW, can only be installed vertically to the pipeline (see 2-A).
- The pump installation shall not allow the system pipeline tensile force to be transferred to the pump body.
- The pump should be installed in the environment with sufficient cooling and the cooling air shall not be above 40°C.
- If the pumps are installed outdoors, there should be covers to protect electric components from water.
- For the convenience of maintenance, there should be enough space above and below the pumps. Minimum 300mm shall be kept for pumps with motor power lower than 5.5kW, and minimum 1000mm for pumps with motor power higher than 5.5kW (including 5.5kW). (See 2-B)
- To prevent noises and vibration and ensure the best operation, anti-vibration base shall be used in installation. Generally, cement base with the weight equal or bigger than 1.5 X pump weight shall be adopted. (See 2-C).
- For TF, TX 32 to TF, TX 150, pumps with bases or without bases are both available for customers requirements. (See appendix TF, TX 32-TF, TX 150 for base dimensions).

Installation requirements

For power ≤2.2kW

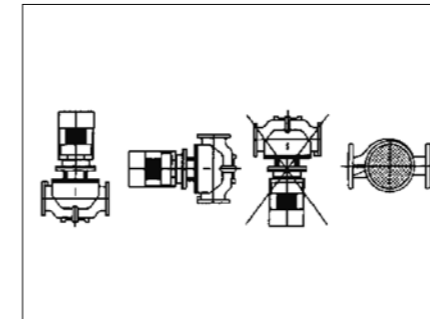

For power >2.2kW

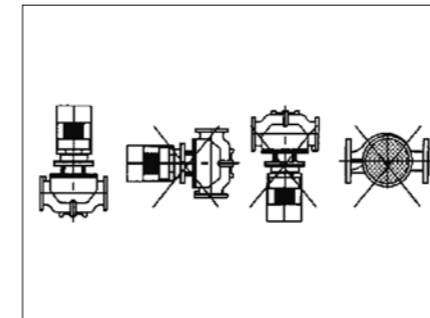
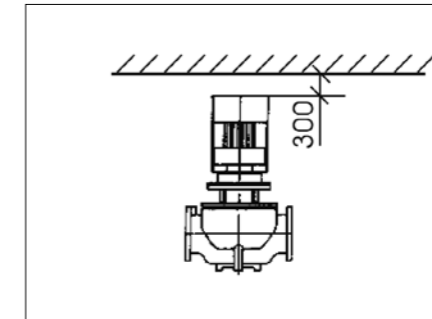

Figure 2-A

For power <5.5kW



For power ≥5.5kW

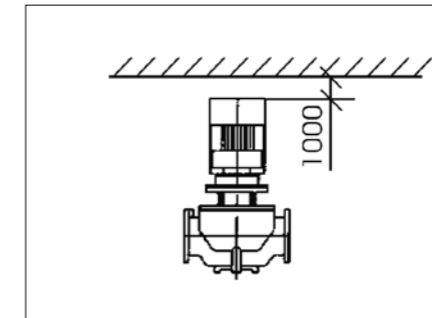

Figure 2-B

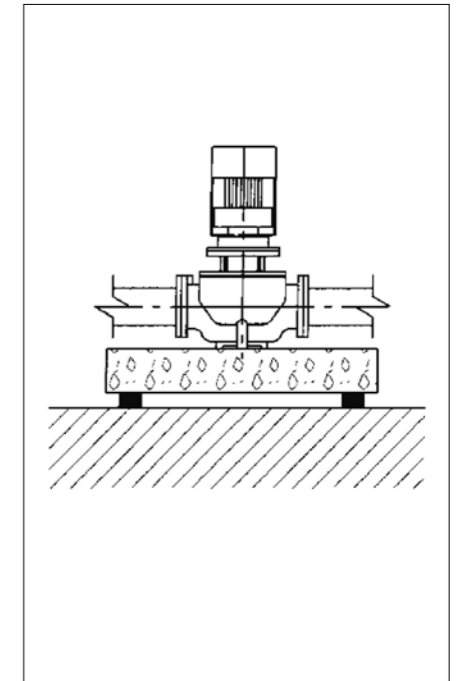

Figure 2-C

Product structure and component material

The design of the pump is pump and motor. Pump part can be pulled out. The TDROO series are equipped with standard motor and mechanical seal. Motor is TEFC standard motor. Its major dimensions are in conformity with JB/

T8680 standard.

The pump body is equal to a section of pipeline. While in maintenance, blind flange can be used to seal to pump cover which enable the normal operation of pumps.

The pump head is to connect motor and the pump. 'O' ring is used to seal the pump head and the pump.

See Table 4 for component materials.

The flange connection dimension are in conformity with the related provisions PN16 in GB/T 17241.6 or ISO7005-2/ DIN2501.

The inlet and outlet diameters are in conformity with related standard dimensions.

**Section drawing TF, TX 32 ~ TF, TX 150
Extension Shaft**

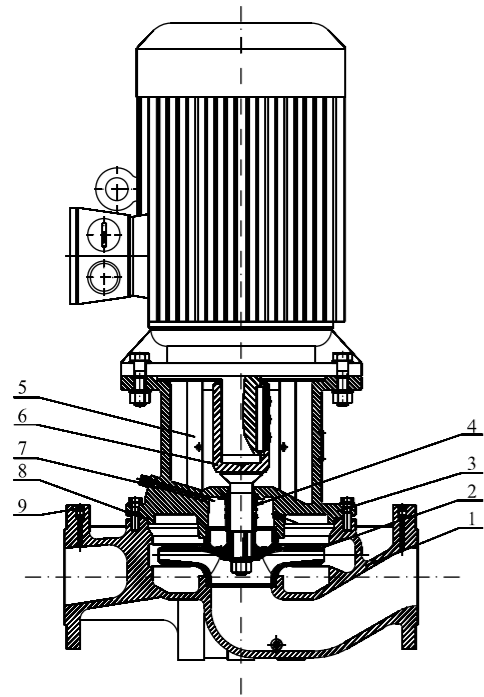

**Material TF, TX 32 ~ TF, TX150
Extension Shaft**

N°	Parts	Material
1	Pump body	GG20
2	Impeller	GG20/AISI304
3	Pump head	GG20
4	Mechanical seal	Carbon /Silicon Carbide
5	Guard plate	06Cr19Ni10
6	Shaft	AISI420
7	Air release bolt	06Cr19Ni10
8	Ring	NBR
9	Plug	06Cr19Ni10

**Section drawing TF, TX 200 ~ TF, TX 250
easy maintenance structure**

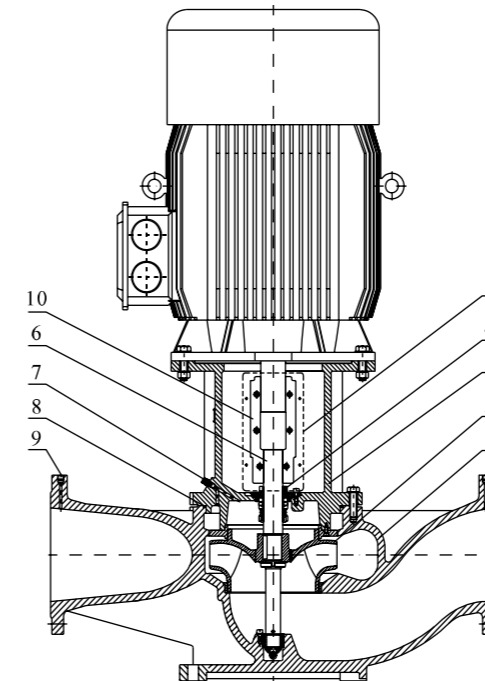

**Material TF, TX 200 ~ TF, TX 250
easy maintenance structure**

N°	Parts	Material
1	Pump body	GG20
2	Impeller	GG20/AISI304
3	Pump head	GG20
4	Mechanical seal	Carbon /Silicon Carbide
5	Guard plate	06Cr19Ni10
6	Shaft	AISI420
7	Air release valve	06Cr19Ni10
8	O ring	NBR
9	Plug	06Cr19Ni10
10	Coupling	Cast Steel ZG270-500

**Section drawing TF, TX 125 ~ TF, TX 150
easy maintenance structure**

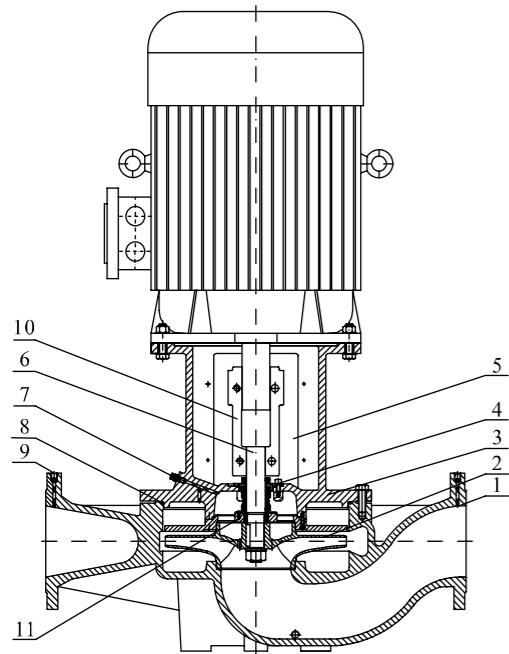

**Material TF, TX 125 ~ TF, TX 150
easy maintenance structure**

N°	Parts	Material
1	Pump body	GG20
2	Impeller	GG20/AISI304
3	Pump head	GG20
4	Mechanical seal	Carbon/Silicon Carbide
5	Guard plate	06Cr19Ni10
6	Shaft	AISI420
7	Air release valve	06Cr19Ni10
8	O ring	NBR
9	Plug	06Cr19Ni10
10	Coupling	Cast Steel ZG270-500
11	Bearing ring	GG20

**Section drawing TF, TX 300
easy maintenance structure**

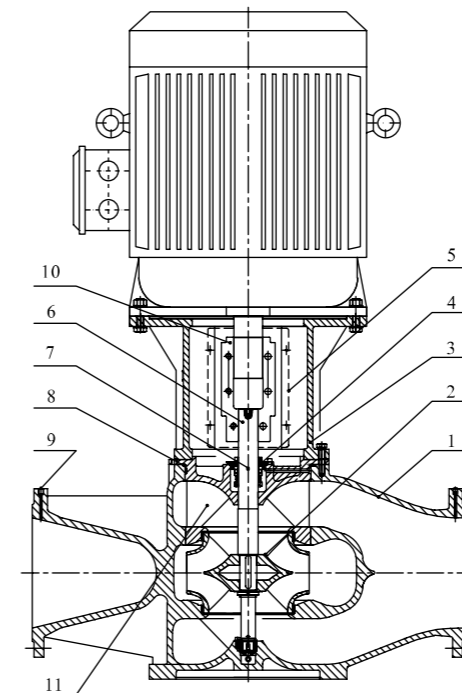

**Material TF, TX 300
easy maintenance structure**

N°	Parts	Material
1	Pump body	GGG50
2	Impeller	GG20
3	Pump head	GG20
4	Mechanical seal	Carbon /Silicon Carbide
5	Guard plate	06Cr19Ni10
6	Shaft	AISI420
7	Air release valve	06Cr19Ni10
8	O ring	NBR
9	Plug	06Cr19Ni10
10	Coupling	ZG270-500
11	Pump cover	GGG50

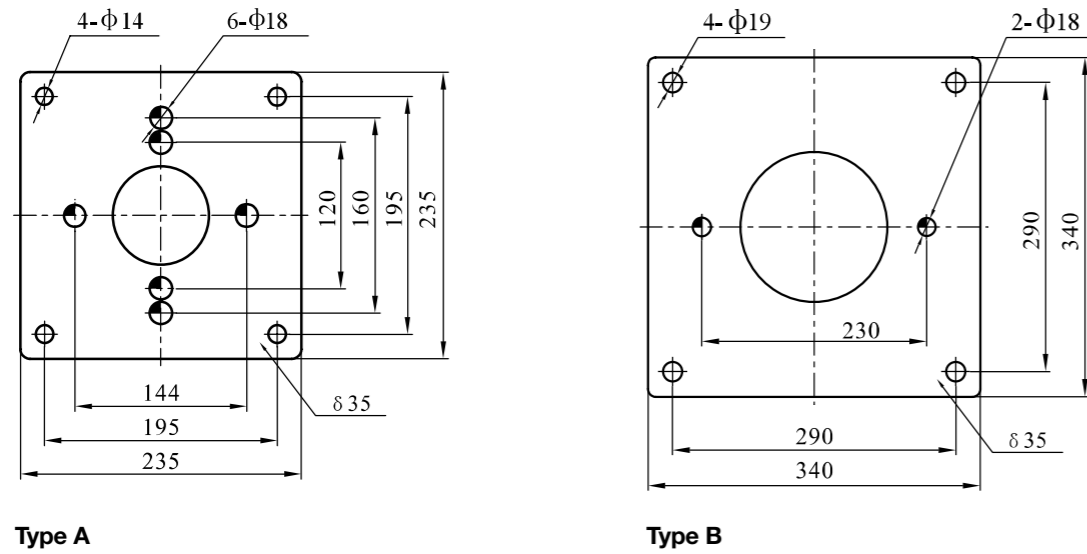

50Hz

N°	Product model	Base plate type	N°	Product model	Base plate type	N°	Product model	Base plate type
1	TF, TX 32-8-18	A	27	TF, TX 50-50-60	A	53	TF, TX 100-50-9	A
2	TF, TX 32-12.5-21	A	28	TF, TX 50-50-70	A	54	TF, TX 100-60-15	A
3	TF, TX 32-12.5-26	A	29	TF, TX 50-50-81	A	55	TF, TX 100-80-17	A
4	TF, TX 32-12.5-33	A	30	TF, TX 65-25-37	A	56	TF, TX 100-78-22	A
5	TF, TX 32-12.5-40	A	31	TF, TX 65-25-48	A	57	TF, TX 100-100-27	A
6	TF, TX 32-12.5-50	A	32	TF, TX 65-30-15	A	58	TF, TX 100-100-33	A
7	TF, TX 40-12.5-16	A	33	TF, TX 65-30-20	A	59	TF, TX 100-100-40	B
8	TF, TX 40-12.5-21	A	34	TF, TX 65-40-22	A	60	TF, TX 100-100-48	B
9	TF, TX 40-20-20	A	35	TF, TX 65-40-30	A	61	TF, TX 100-130-52	B
10	TF, TX 40-18-26	A	36	TF, TX 65-50-34	A	62	TF, TX 125-120-11	B
11	TF, TX 40-25-30	A	37	TF, TX 65-50-41	A	63	TF, TX 125-120-14	B
12	TF, TX 40-25-36	A	38	TF, TX 65-50-51	A	64	TF, TX 125-140-19	B
13	TF, TX 40-25-48	A	39	TF, TX 65-50-61	A	65	TF, TX 125-160-22	B
14	TF, TX 50-12.5-32	A	40	TF, TX 65-50-68	A	66	TF, TX 125-160-28	B
15	TF, TX 50-12.5-39	A	41	TF, TX 65-50-85	A	67	TF, TX 125-160-32	B
16	TF, TX 50-12.5-49	A	42	TF, TX 80-50-41	A	68	TF, TX 125-160-40	B
17	TF, TX 50-12.5-59	A	43	TF, TX 80-50-48	A	69	TF, TX 125-160-48	B
18	TF, TX 50-12.5-80	A	44	TF, TX 80-50-13	A	70	TF, TX 150-200-12.5	B
19	TF, TX 50-16-12	A	45	TF, TX 80-50-18	A	71	TF, TX 150-200-17	B
20	TF, TX 50-20-15	A	46	TF, TX 80-50-23	A	72	TF, TX 150-200-22	B
21	TF, TX 50-25-18	A	47	TF, TX 80-50-29	A	73	TF, TX 150-200-25	B
22	TF, TX 50-25-24	A	48	TF, TX 80-70-32	A	74	TF, TX 150-200-33	B
23	TF, TX 50-30-28	A	49	TF, TX 80-80-38	A	75	TF, TX 150-200-40	B
24	TF, TX 50-30-35	A	50	TF, TX 80-80-47	A	76	TF, TX 150-200-50	B
25	TF, TX 50-35-40	A	51	TF, TX 80-80-54	A			
26	TF, TX 50-40-50	A	52	TF, TX 80-80-67	A			

N°	Product model	Base plate type	N°	Product model	Base plate type	N°	Product model	Base plate type
1	TF, TX 32-7-24	A	25	TF, TX 50-45-84	A	49	TF, TX 100-80-17	A
2	TF, TX 32-10-27	A	26	TF, TX 50-50-98	A	50	TF, TX 100-80-22	A
3	TF, TX 32-15-30	A	27	TF, TX 65-30-20	A	51	TF, TX 100-100-25	B
4	TF, TX 32-15-38	A	28	TF, TX 65-30-25	A	52	TF, TX 100-100-32	B
5	TF, TX 32-15-46	A	29	TF, TX 65-30-32	A	53	TF, TX 100-120-34	B
6	TF, TX 32-20-57	A	30	TF, TX 65-35-38	A	54	TF, TX 100-120-38	B
7	TF, TX 32-20-72	A	31	TF, TX 65-35-46	A	55	TF, TX 100-130-52	B
8	TF, TX 40-12-20	A	32	TF, TX 65-35-55	A	56	TF, TX 100-130-60	B
9	TF, TX 40-15-24	A	33	TF, TX 65-50-60	A	57	TF, TX 125-120-11	B
10	TF, TX 40-15-28	A	34	TF, TX 65-50-73	A	58	TF, TX 125-120-14	B
11	TF, TX 40-20-32	A	35	TF, TX 65-60-85	A	59	TF, TX 125-120-20	B
12	TF, TX 40-25-35	A	36	TF, TX 65-60-100	A	60	TF, TX 125-120-24	B
13	TF, TX 40-25-42	A	37	TF, TX 80-50-12	A	61	TF, TX 125-140-28	B
14	TF, TX 40-25-65	A	38	TF, TX 80-50-17	A	62	TF, TX 125-150-32	B
15	TF, TX 40-25-76	A	39	TF, TX 80-60-20	A	63	TF, TX 125-150-38	B
16	TF, TX 40-30-85	A	40	TF, TX 80-60-26	A	64	TF, TX 125-180-40	B
17	TF, TX 50-20-20	A	41	TF, TX 80-80-30	A	65	TF, TX 125-180-46	B
18	TF, TX 50-20-27	A	42	TF, TX 80-80-38	A	66	TF, TX 150-160-15	B
19	TF, TX 50-20-34	A	43	TF, TX 80-80-47	A	67	TF, TX 150-180-18	B
20	TF, TX 50-20-40	A	44	TF, TX 80-80-52	A	68	TF, TX 150-200-20	B
21	TF, TX 50-30-42	A	45	TF, TX 80-80-70	A	69	TF, TX 150-200-24	B
22	TF, TX 50-35-51	A	46	TF, TX 80-80-81	A	70	TF, TX 150-200-32	B
23	TF, TX 50-45-62	A	47	TF, TX 100-50-11	A	71	TF, TX 150-200-36	B
24	TF, TX 50-45-72	A	48	TF, TX 100-60-15	A	72	TF, TX 150-200-44	B

Remark: Base plate is optional part, need to note when order.

TF, TX 32 50Hz

Performance curve ISO9906:2012, 3B

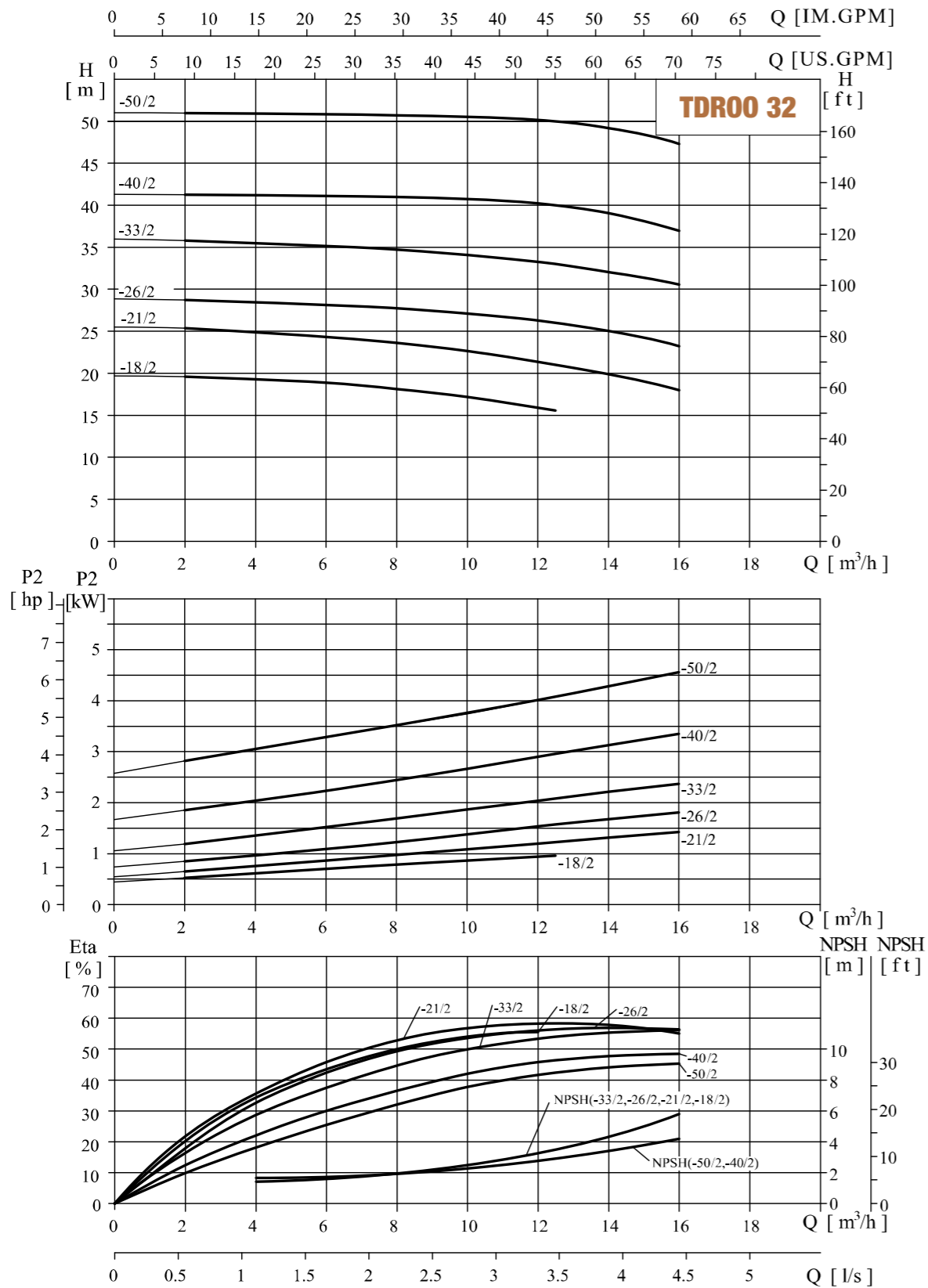

Performance table

Model (2900rpm)	Driving motor (kW)		Q (m³/h)	2	4	6	8	10	12.5	14	16
	(kW)	(hp)									
TF, TX 32-8-18	1.1	1.5	H (m)	19.6	19.3	18.9	18	17.2	15.6		
TF, TX 32-12.5-21	1.5	2		25.3	24.9	24.3	23.6	22.6	21	19.9	18
TF, TX 32-12.5-26	2.2	3		28.7	28.4	28.1	27.7	27.1	26	25	23.2
TF, TX 32-12.5-33	3	4		35.8	35.5	35.1	34.7	34.1	33	32.1	30.6
TF, TX 32-12.5-40	4	5.5		41.3	41.2	41.1	41	40.7	40	39.1	37
TF, TX 32-12.5-50	5.5	7.5		51	50.9	50.8	50.7	50.5	50	49.2	47.3

Installation sketch

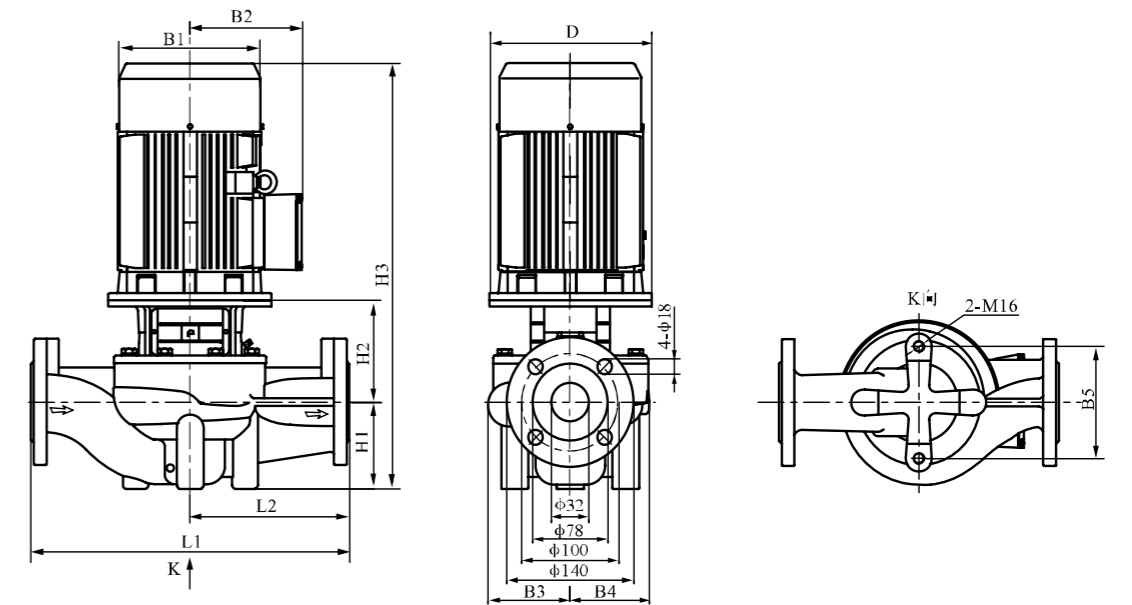

Size and weight

Model (2900rpm)	Size (mm)											Weight (kg)
	D	B1	B2	B3	B4	B5	H1	H2	H3	L1	L2	
TF, TX 32-8-18	120	151	125	101	101	144	90	135	469	320	160	34
TF, TX 32-12.5-21	140	171	137	101	101	144	90	137	514	320	160	38
TF, TX 32-12.5-26	140	171	137	101	101	144	90	137	514	320	160	42
TF, TX 32-12.5-33	160	196	150	109	109	144	90	145	572	340	170	52
TF, TX 32-12.5-40	160	214	169	128	128	144	100	151	593	360	ISO	65
TF, TX 32-12.5-50	200	257	190	128	128	144	100	173	656	360	180	84

TF, TX 40 50Hz

Performance curve ISO9906:2012, 3B

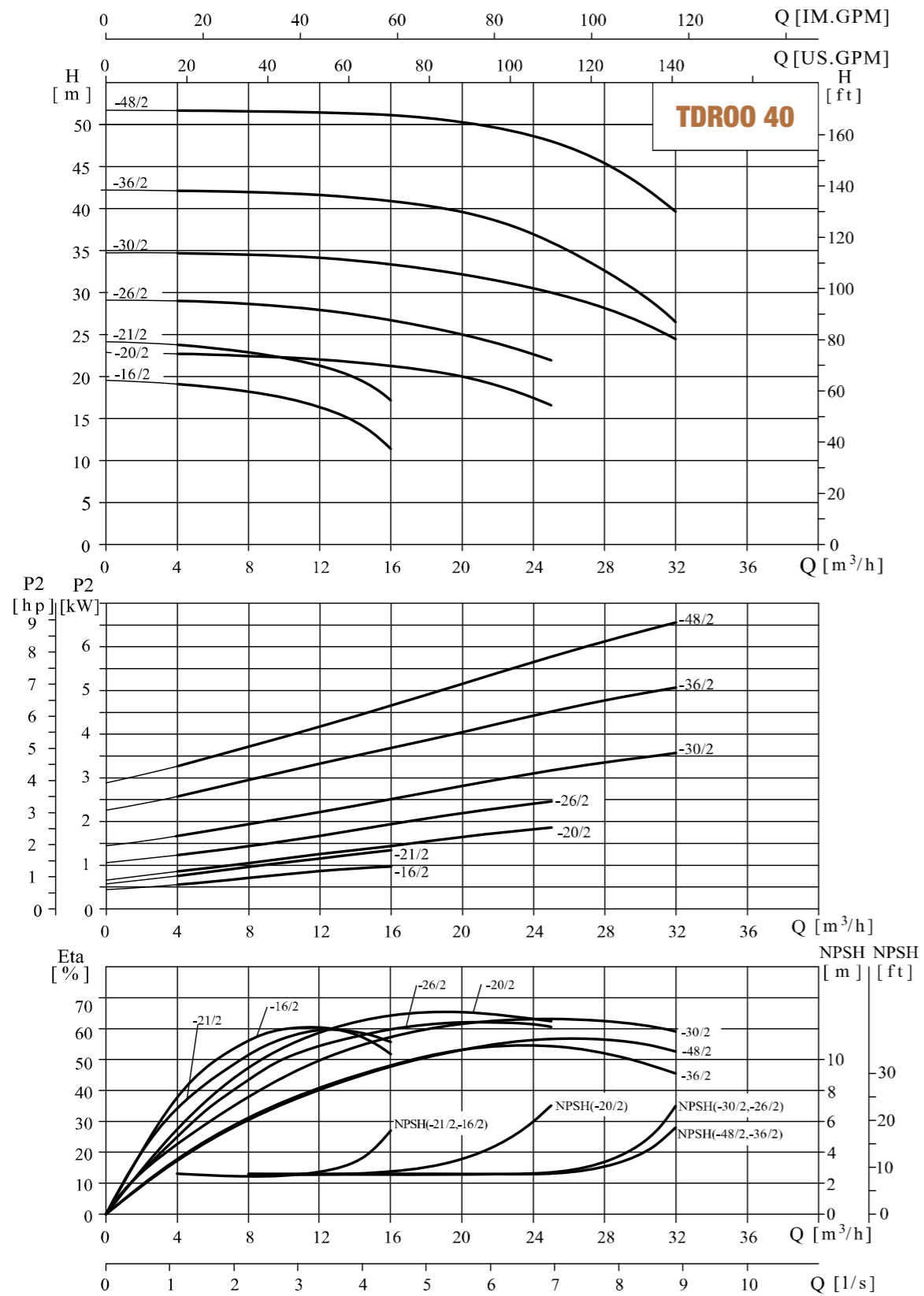

Performance table

Model (2900rpm)	Driving motor (kW)		Q (m³/h)	4	8	12.5	16	20	25	28	32
	(kW)	(hp)									
TF, TX 40-12.5-16	1.1	1.5	H (m)	19.1	18.2	16	11.4				
TF, TX 40-12.5-21	1.5	2		23.8	22.9	21	17.1				
TF, TX 40-20-20	2.2	3		22.7	22.5	22	21.3	20	16.6		
TF, TX 40-18-26	3	4		29	28.6	27.8	26.7	25	21.9		
TF, TX 40-25-30	4	5.5		34.7	34.5	34.1	33.4	32.2	30	28.2	24.5
TF, TX 40-25-36	5.5	7.5		42.1	42	41.5	40.9	39.6	36	32.6	26.5
TF, TX 40-25-48	7.5	10		51.6	51.6	51.4	51.1	50.3	48	45.4	39.6

Installation sketch

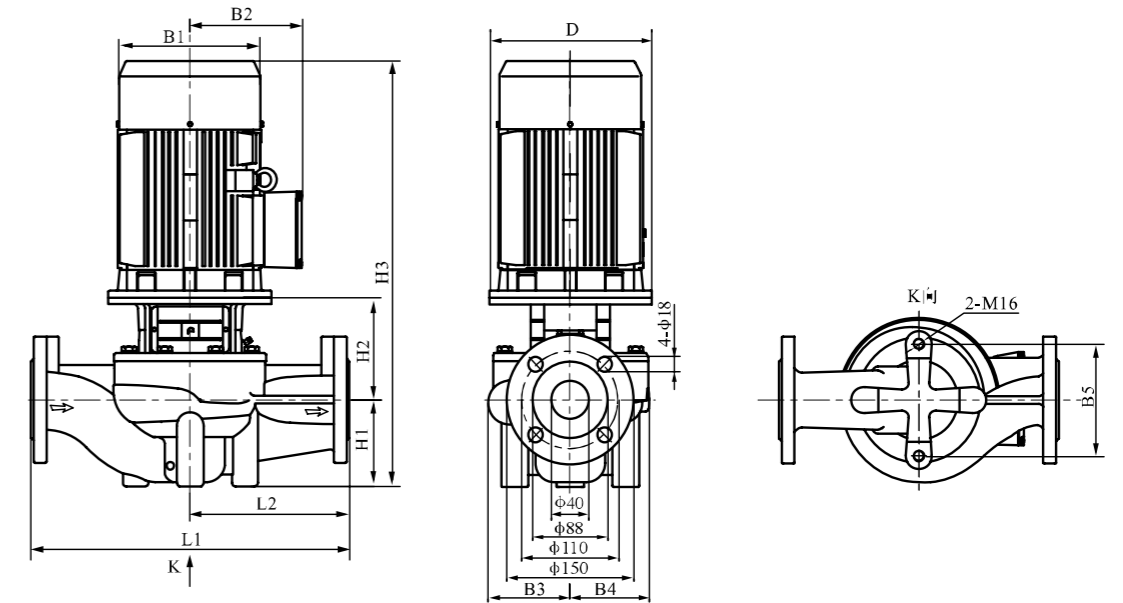

Size and weight

Model (2900rpm)	Size (mm)										Weight (kg)	
	D	B1	B2	B3	B4	B5	H1	H2	H3	L1		L2
TF, TX 40-12.5-16	120	151	125	98	95	120	68	139	451	320	160	32
TF, TX 40-12.5-21	140	171	137	98	95	120	68	149	504	320	160	38
TF, TX 40-20-20	140	171	137	105	95	144	85	144	516	320	160	43
TF, TX 40-18-26	160	196	150	116	109	144	85	156	578	340	170	54
TF, TX 40-25-30	160	214	169	116	109	144	85	156	583	340	170	62
TF, TX 40-25-36	200	257	190	133	128	144	90	181	654	380	190	85
TF, TX 40-25-48	200	257	190	133	128	144	90	181	654	380	190	94

TF, TX 50 50Hz

Performance curve ISO9906:2012, 3B

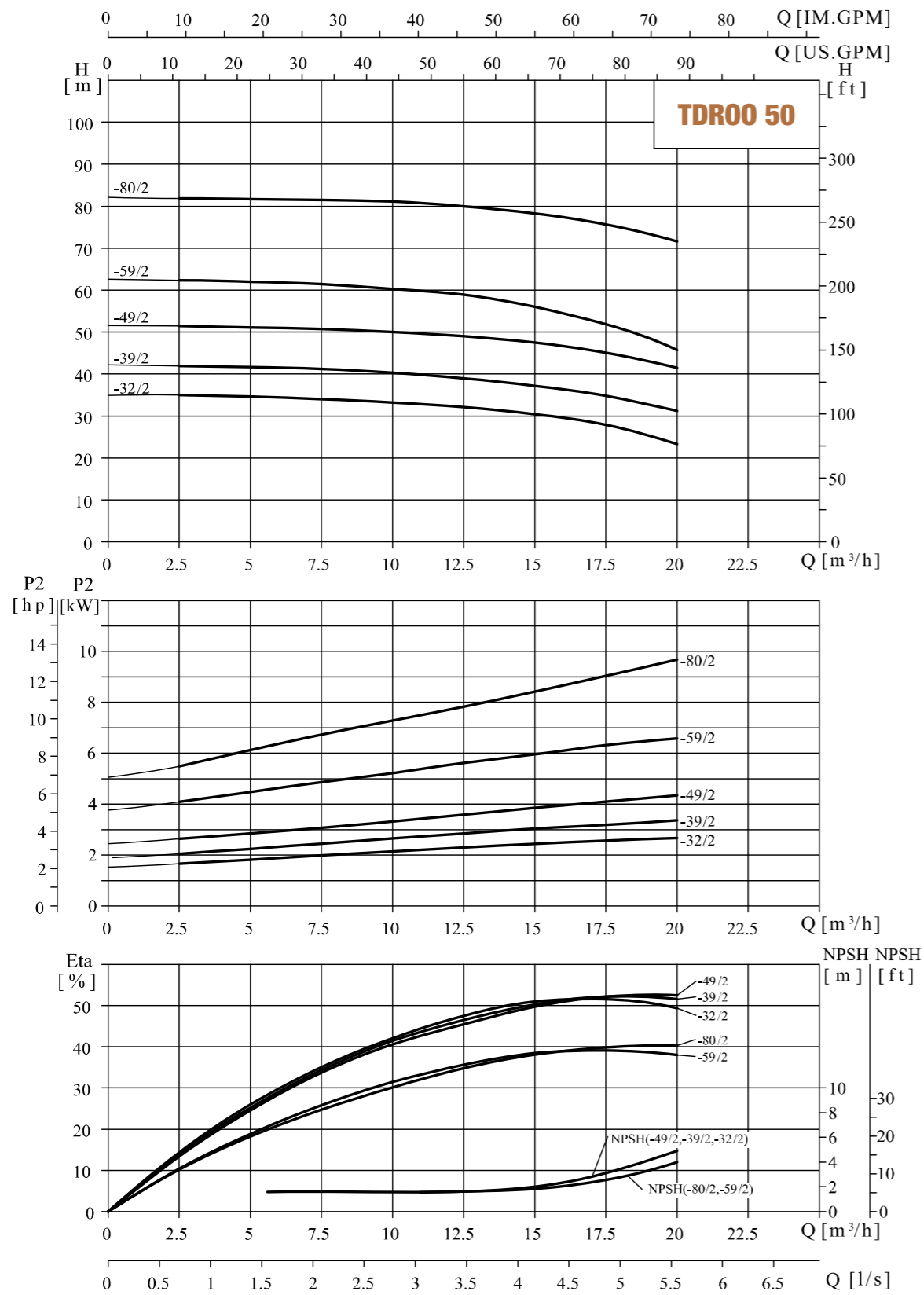

Performance table

Model (2900rpm)	Driving motor (kW)		Q (m³/h)	2.5	5	7.5	10	12.5	15	17.5	20
	(kW)	(hp)									
TF, TX 50-12.5-32	3	4	H (m)	35	34.6	34	33.2	32	30.5	27.9	23.3
TF, TX 50-12.5-39	4	5.5		41.9	41.7	41.3	40.2	39	37.2	34.8	31.2
TF, TX 50-12.5-49	5.5	7.5		51.6	51.2	50.7	50	49	47.5	45.1	41.5
TF, TX 50-12.5-59	7.5	10		62.4	62.1	61.4	60.3	59	56.1	51.9	45.7
TF, TX 50-12.5-80	11	15		81.9	81.7	81.5	81.1	80	78.3	75.7	71.6

Installation sketch

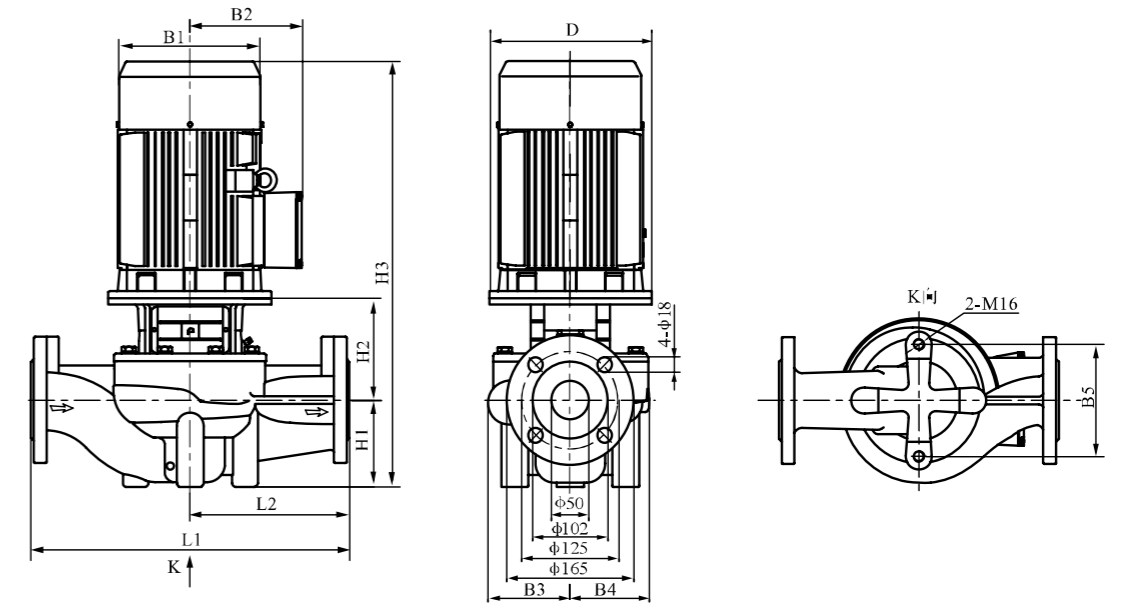

Size and weight

Model (2900rpm)	Size (mm)											Weight (kg)
	D	B1	B2	B3	B4	B5	H1	H2	H3	L1	L2	
TF, TX 50-12.5-32	160	196	150	128	128	144	105	150	592	400	200	64
TF, TX 50-12.5-39	160	214	169	128	128	144	105	150	597	400	200	71
TF, TX 50-12.5-49	200	257	190	128	128	144	105	172	660	400	200	88
TF, TX 50-12.5-59	200	257	190	163	163	144	105	178	666	440	220	112
TF, TX 50-12.5-80	350	314	261	163	163	144	105	222	783	440	220	184

TF, TX 50 50Hz

Performance curve ISO9906:2012, 3B

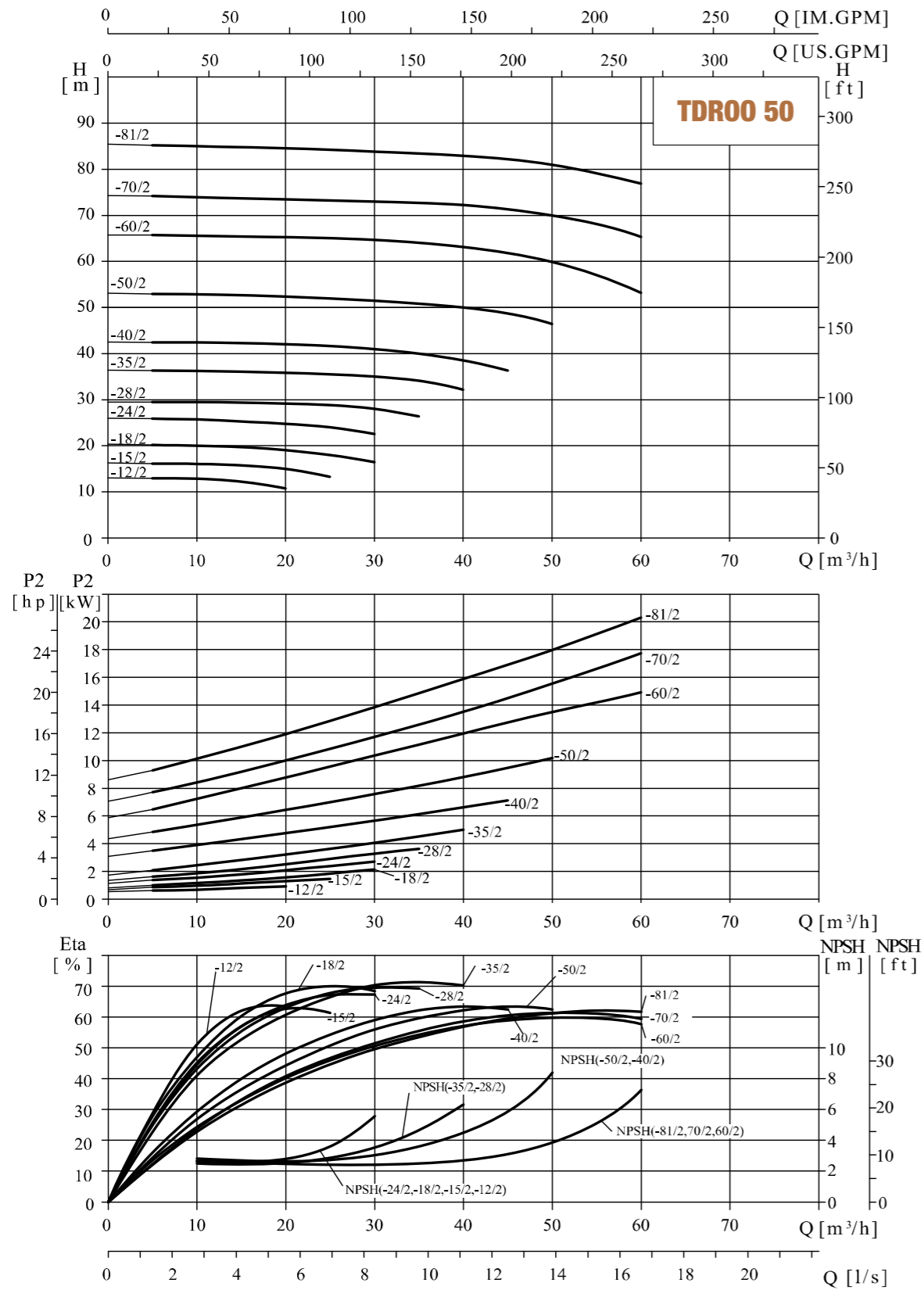

Performance table

Model (2900rpm)	Driving motor (kW)		Q (m³/h)	5	10	16	20	25	30	35	40	45	50	60	
	(kW)	(hp)													
TF, TX 50-16-12	1.1	1.5		13	12.9	12	10.7								
TF, TX 50-20-15	1.5	2		16.1	16.1	15.6	15	13.3							
TF, TX 50-25-18	2.2	3		20.2	20	19.6	19	18	16.4						
TF, TX 50-25-24	3	4		25.9	25.7	25.2	24.8	24	22.6						
TF, TX 50-30-28	4	5.5		29.5	29.5	29.3	29.2	28.8	28	26.4					
TF, TX 50-30-35	5.5	7.5		36.3	36.2	36	35.9	35.5	35	34.1	32.2				
TF, TX 50-35-40	7.5	10		42.5	42.4	42.2	42.1	41.7	41	40	38.5	36.4			
TF, TX 50-40-50	11	15		53	52.9	52.6	52.4	52	51.5	50.9	50	48.7	46.4		
TF, TX 50-50-60	15	20		65.8	65.7	65.7	65.6	65.3	64.7	63.9	62.8	61.6	60	53.2	
TF, TX 50-50-70	18.5	25		73.7	73.6	73.4	73.3	73.1	72.9	72.5	72	71.2	70	65.4	
TF, TX 50-50-81	22	30		85.5	85.3	85	84.8	84.5	84	83.5	82.8	82.1	81	77.1	

Installation sketch

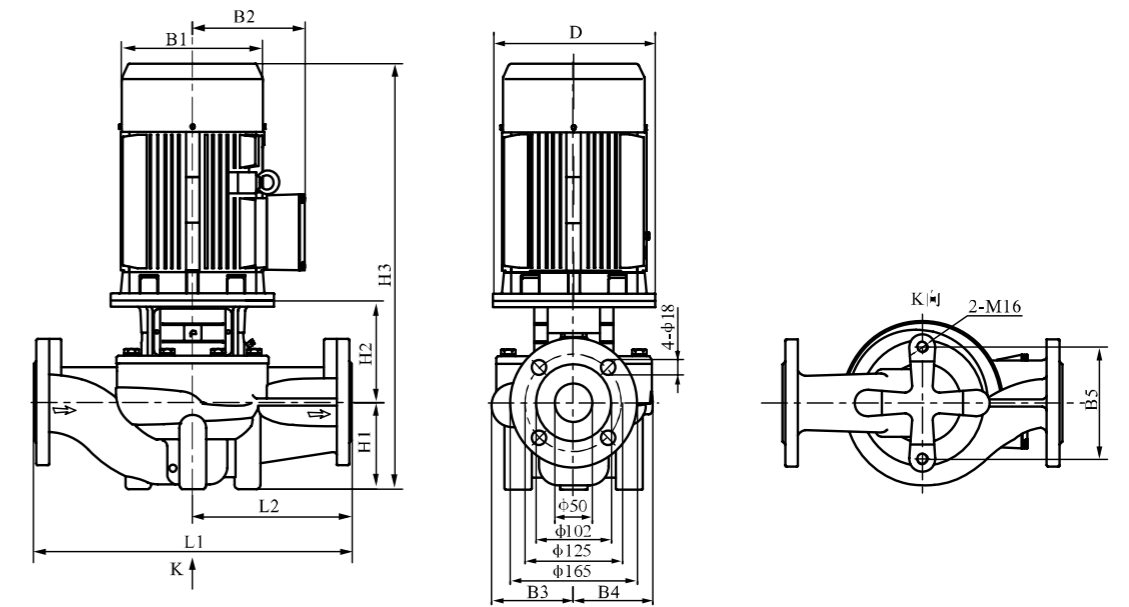

Size and weight

Model (2900rpm)	Size (mm)											Weight (kg)
	D	B1	B2	B3	B4	B5	H1	H2	H3	L1	L2	
TF, TX 50-16-12	120	151	125	114	101	144	105	135	484	340	170	37
TF, TX 50-20-15	140	171	137	114	101	144	105	137	529	340	170	42
TF, TX 50-25-18	140	171	137	114	101	144	105	137	529	340	170	45
TF, TX 50-25-24	160	196	150	114	101	144	105	147	589	340	170	55
TF, TX 50-30-28	160	214	169	118	109	144	105	152	599	340	170	64
TF, TX 50-30-35	200	257	190	118	109	144	105	175	663	340	170	81
TF, TX 50-35-40	200	257	190	142	138	144	105	175	663	400	200	98
TF, TX 50-40-50	350	314	261	142	138	144	105	225	830	400	200	173
TF, TX 50-50-60	350	314	261	171	163	144	115	225	S40	440	220	196
TF, TX 50-50-70	350	314	261	171	163	144	115	225	884	440	220	203
TF, TX 50-50-81	350	355	273	171	163	144	115	225	917	440	220	256

TF, TX 65 50Hz

Performance curve ISO9906:2012, 3B

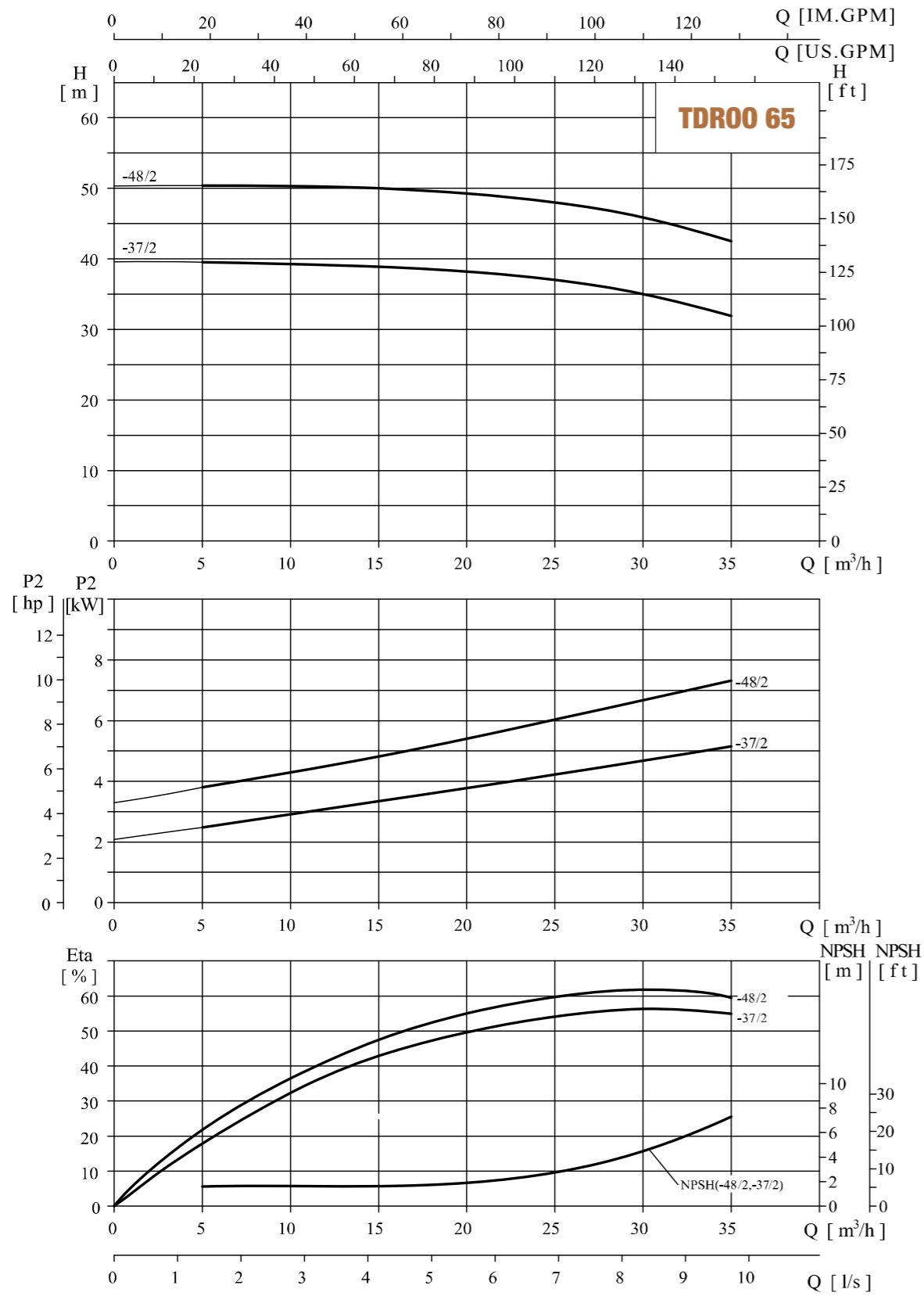

Performance table

Model (2900rpm)	Driving motor (kW)		Q (m³/h)	5	10	15	20	25	30	35
	(kW)	(hp)								
TF, TX 65-25-37	5.5	7.5	H (m)	39.6	39.3	39	38.2	37	35	32.1
TF, TX 65-25-48	7.5	10		50.4	50.3	50	49.3	48	45.9	42.6

Installation sketch

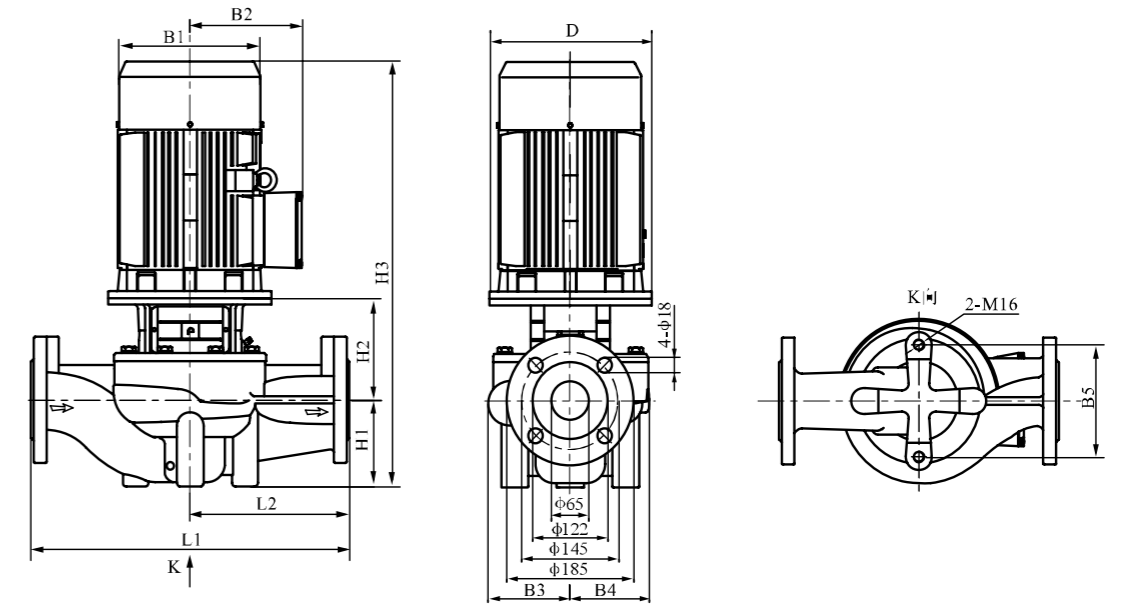

Size and weight

Model (2900rpm)	Size (mm)											Weight (kg)
	D	B1	B2	B3	B4	B5	H1	H2	H3	L1	L2	
TF, TX 65-25-37	200	257	190	128	128	144	105	180	668	400	200	90
TF, TX 65-25-48	200	257	190	128	128	144	105	180	668	400	200	98

TF, TX 65 50Hz

Performance curve ISO9906:2012, 3B

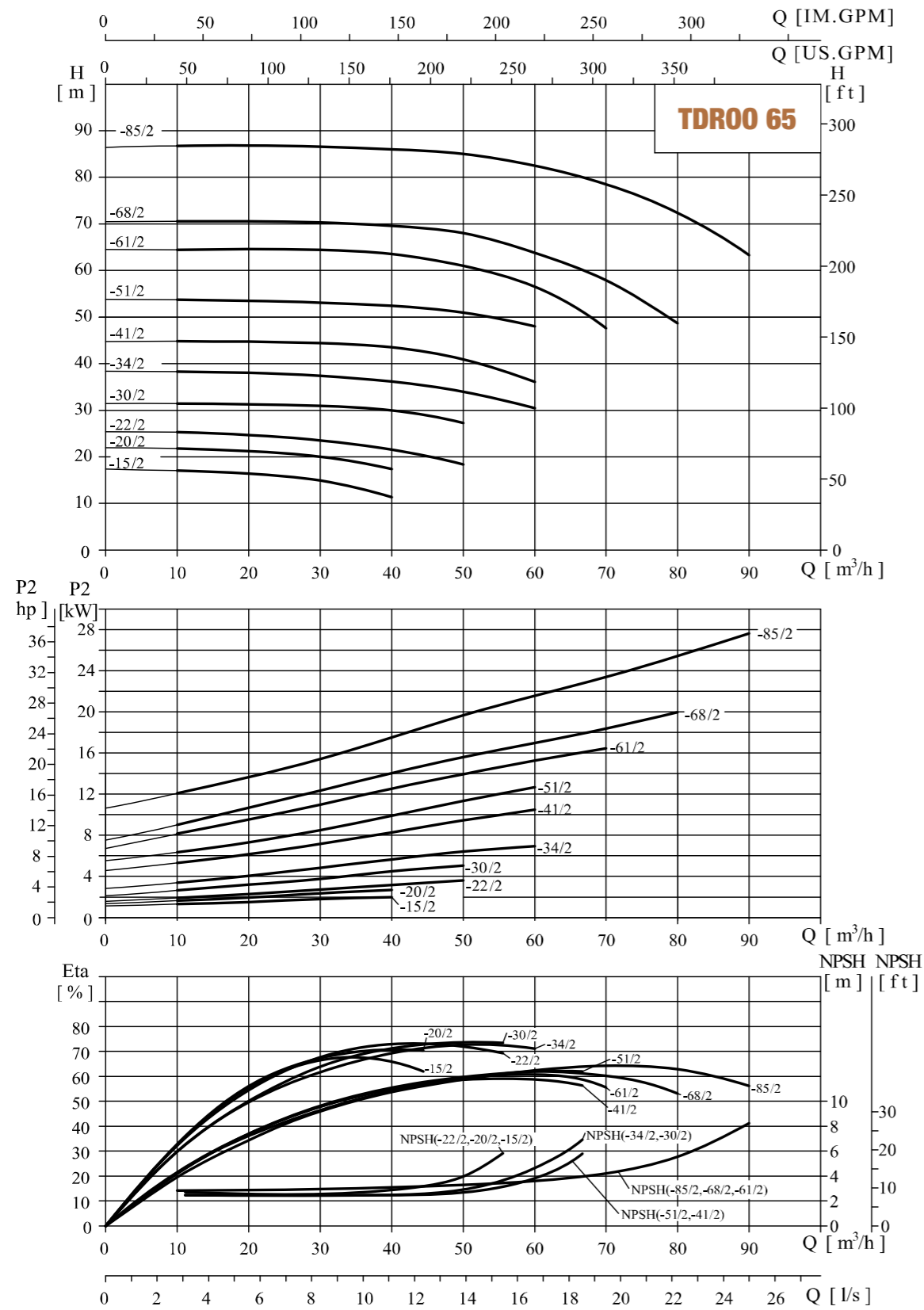

Performance table

Model (2900rpm)	Driving motor (kW)		Q (m³/h)	10	20	30	40	50	60	70	80	90
	(kW)	(hp)										
TF, TX 65-30-15	2.2	3		17.1	16.4	15	11.3					
TF, TX 65-30-20	3	4		21.8	21.2	20	17.4					
TF, TX 65-40-22	4	5.5		25.1	24.8	23.9	22	18.4				
TF, TX 65-40-30	5.5	7.5		31.5	31.3	31	30	27.3				
TF, TX 65-50-34	7.5	10		38.3	38	37.4	36.1	34	30.5			
TF, TX 65-50-41	11	15		44.8	44.7	44.4	43.5	41	36.1			
TF, TX 65-50-51	15	20		53.7	53.5	53.1	52.4	51	48			
TF, TX 65-50-61	18.5	25		64.5	64.6	64.4	63.5	61	56.5	47.6		
TF, TX 65-50-68	22	30		70.5	70.5	70.3	69.6	68	63.8	58	48.6	
TF, TX 65-50-85	30	40		86.7	86.7	86.5	86	85	82.5	78.5	72.4	63.3

Installation sketch

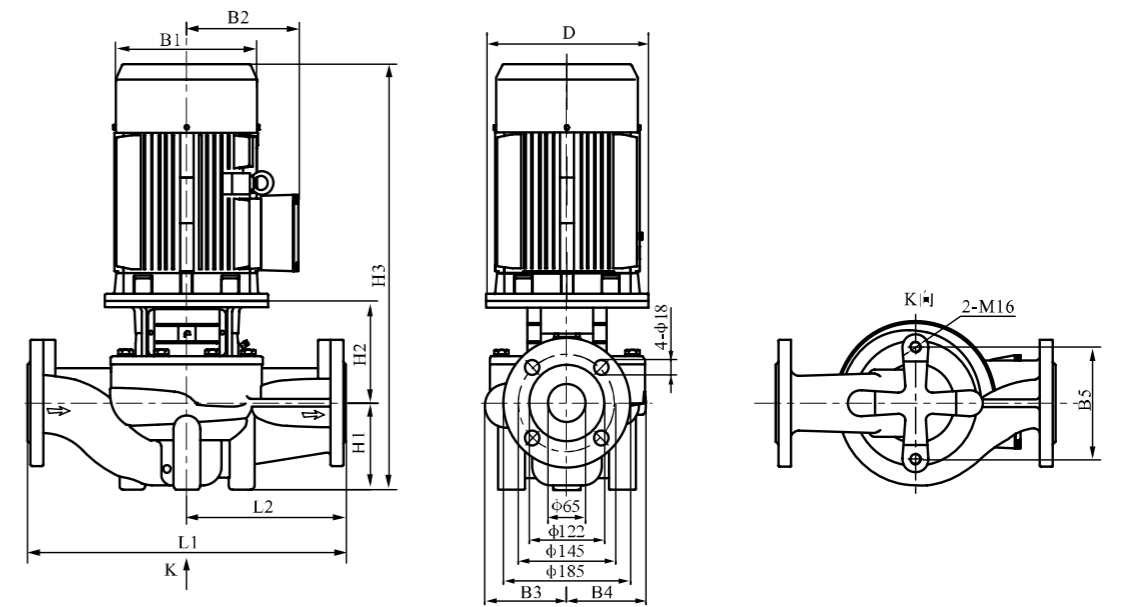

Size and weight

Model (2900rpm)	Size (mm)											Weight (kg)
	D	B1	B2	B3	B4	B5	H1	H2	H3	L1	L2	
TF, TX 65-30-15	140	171	137	116	101	144	105	153	545	340	170	48
TF, TX 65-30-20	160	196	150	116	101	144	105	163	605	340	170	57
TF, TX 65-40-22	160	214	169	116	101	144	105	163	610	340	170	64
TF, TX 65-40-30	200	257	190	131	115	144	105	194	682	360	180	85
TF, TX 65-50-34	200	257	190	131	115	144	105	194	682	360	180	94
TF, TX 65-50-41	350	314	261	148	138	144	105	234	839	400	200	173
TF, TX 65-50-51	350	314	261	148	138	144	105	234	839	400	200	188
TF, TX 65-50-61	350	314	261	174	162	160	125	228	897	475	238	208
TF, TX 65-50-68	350	355	273	174	162	160	125	228	930	475	238	260
TF, TX 65-50-85	400	397	314	174	162	160	125	231	1008	475	238	322

TF, TX 80 50Hz

Performance curve ISO9906:2012, 3B

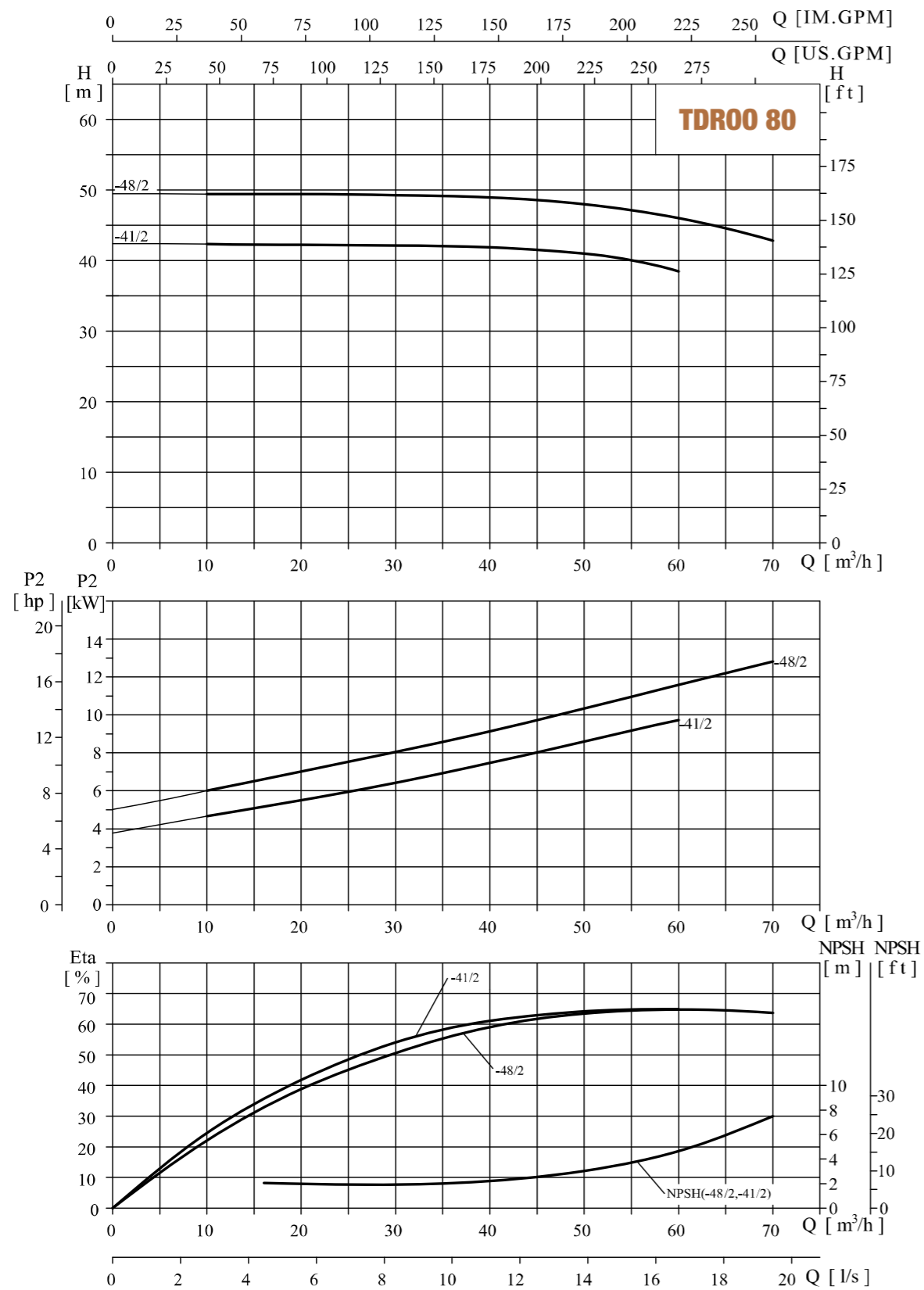

Performance table

Model (2900rpm)	Driving motor (kW)		Q (m³/h)	10	20	30	40	50	60	70
	(kW)	(hp)								
TF, TX 80-50-41	11	15	H (m)	42.3	42.2	42.1	41.8	41	38.4	
TF, TX 80-50-48	15	20		49.4	49.4	49.3	49	48	46	42.8

Installation sketch

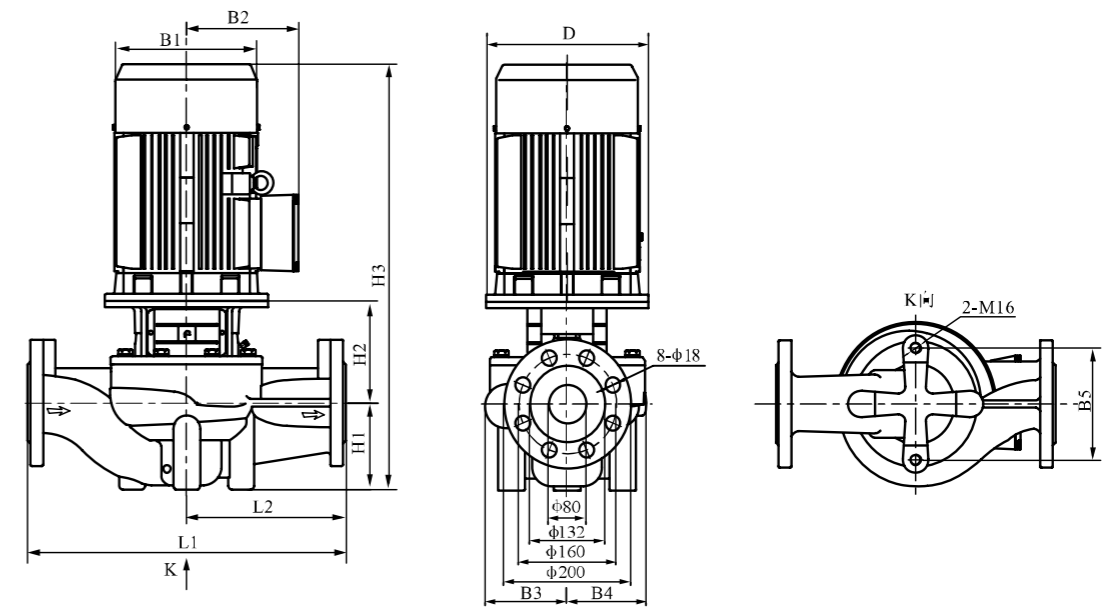

Size and weight

Model (2900rpm)	Size (mm)											Weight (kg)
	D	B1	B2	B3	B4	B5	H1	H2	H3	L1	L2	
TF, TX 80-50-41	350	314	261	137	128	144	115	221	836	500	250	176
TF, TX 80-50-48	350	314	261	137	128	144	115	221	836	500	250	191

TF, TX 80 50Hz

Performance curve ISO9906:2012, 3B

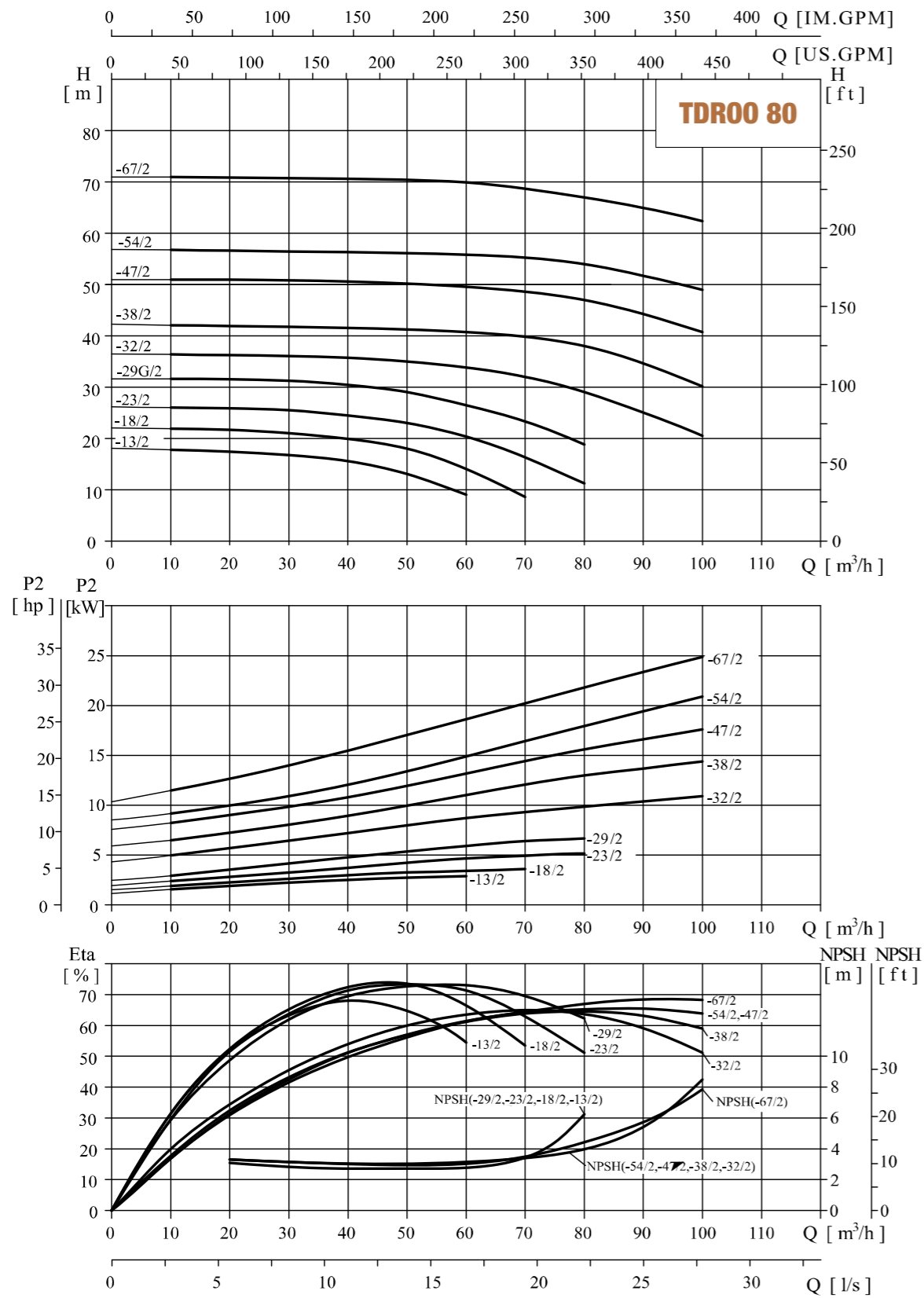

Performance table

Model (2900rpm)	Driving motor (kW)		Q (m³/h)	H (m)												
	(kW)	(hp)		10	20	30	40	50	60	70	80	90	100			
TF, TX 80-50-13	3	4		17.8	17.4	16.7	15.5	13	9.1							
TF, TX 80-50-18	4	5.5		21.9	21.7	21	19.9	18	14	8.6						
TF, TX 80-50-23	5.5	7.5		26	25.9	25.5	24.5	23	20.3	16.3	11.3					
TF, TX 80-50-29	7.5	10		31.6	31.5	31.2	30.4	29	26.5	23.3	18.8					
TF, TX 80-70-32	11	15		36.4	36.2	36.1	35.7	35	33.8	32	29	25	20.5			
TF, TX 80-80-38	15	20		42.1	41.9	41.7	41.5	41.2	40.7	39.8	38	34.6	30.1			
TF, TX 80-80-47	18.5	25		50.9	50.9	50.8	50.6	50.2	49.6	48.6	47	44.3	40.7			
TF, TX 80-80-54	22	30		56.7	56.6	56.5	56.3	56.1	55.8	55.3	54	51.7	49			
TF, TX 80-80-67	30	40		71	70.9	70.8	70.6	70.4	69.9	68.7	67	65	62.3			

Installation sketch

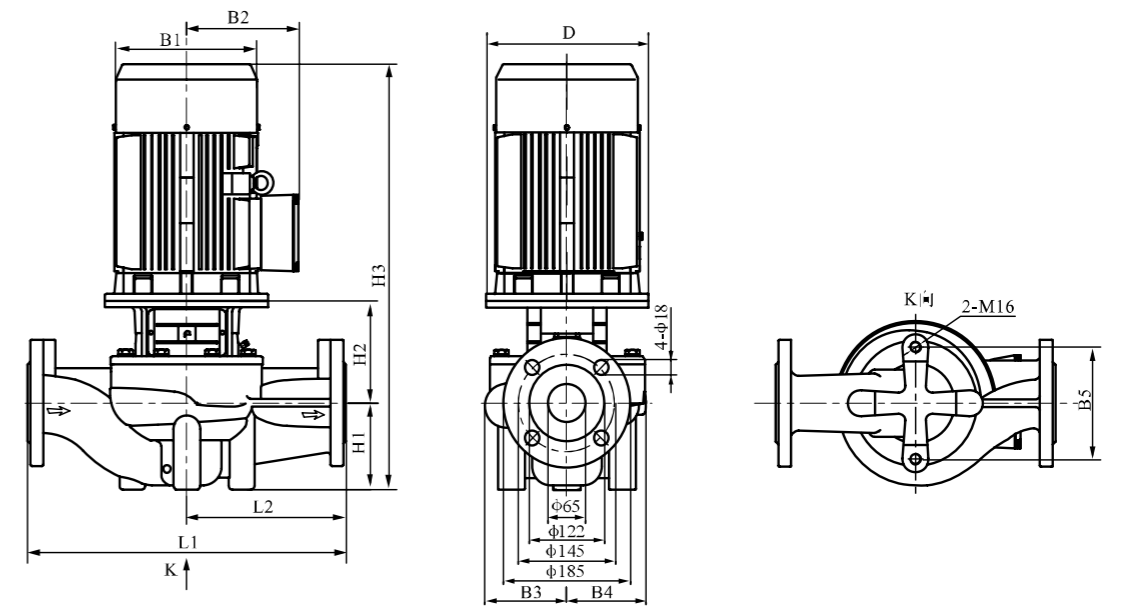

Size and weight

Model (2900rpm)	Size (mm)											Weight (kg)
	D	B1	B2	B3	B4	B5	H1	H2	H3	L1	L2	
TF, TX 80-50-13	160	196	150	134	112	144	105	171	613	400	200	63
TF, TX 80-50-18	160	214	169	134	112	144	105	171	613	400	200	70
TF, TX 80-50-23	200	257	190	134	112	144	105	195	683	400	200	87
TF, TX 80-50-29	200	257	190	134	112	144	105	195	683	400	200	95
TF, TX 80-70-32	350	314	261	159	138	144	115	240	855	450	225	179
TF, TX 80-80-38	350	314	261	159	138	144	115	240	855	450	225	194
TF, TX 80-80-47	350	314	261	159	138	144	115	240	899	450	225	203
TF, TX 80-80-54	350	355	273	159	138	144	115	240	932	450	225	256
TF, TX 80-80-67	400	397	314	180	162	160	115	242	1017	500	250	324

TF, TX 100 50Hz

Performance curve ISO9906:2012, 3B

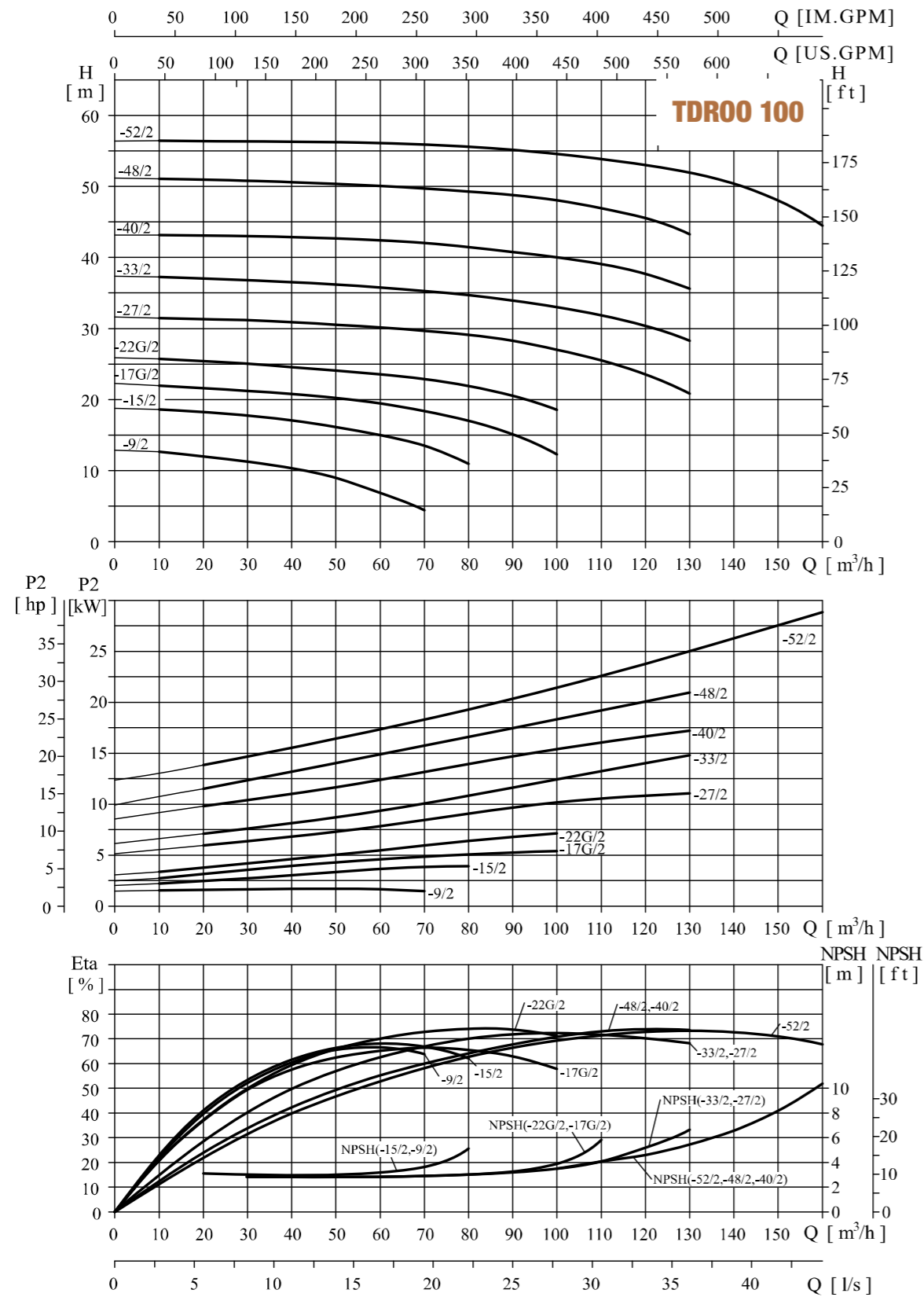

Performance table

Model (2900rpm)	Driving motor (kW)		Q (m³/h)	H (m)															
	(kW)	(hp)		10	20	30	40	50	60	70	80	90	100	110	120	130	145	160	
TF, TX 100-50-9	2.2	3		13.9	13.2	12.2	10.8	9	6.8	4.4									
TF, TX 100-60-15	4	5.5		18.6	18.2	17.7	17.1	16.2	15	13.4	11								
TF, TX 100-80-17	5.5	7.5		21.9	21.6	21.2	20.8	20	19.4	18.4	17	15.1	12.3						
TF, TX 100-78-22	7.5	10		25.7	25.5	25	24.6	24.1	23.6	22.9	21.9	20.5	18.6						
TF, TX 100-100-27	11	15		31.5	31.3	31.1	30.9	30.7	30.3	29.8	29.2	28.2	27	25.5	23.6	20.8			
TF, TX 100-100-33	15	20		37.1	37	36.8	36.6	36.2	35.8	35.3	34.7	33.9	33	31.7	30.1	27.9			
TF, TX 100-100-40	18.5	25		43.3	43.2	43.1	42.9	42.7	42.4	42.1	41.6	40.9	40	38.9	37.4	35.3			
TF, TX 100-100-48	22	30		51.2	51.1	51	50.8	50.6	50.3	49.9	49.4	48.8	48	46.9	45.3	43.2			
TF, TX 100-130-52	30	40		56.4	56.4	56.3	56.3	56.2	56.1	55.9	55.6	55.1	54.5	53.8	53.1	52	49.3	44.5	

Installation sketch

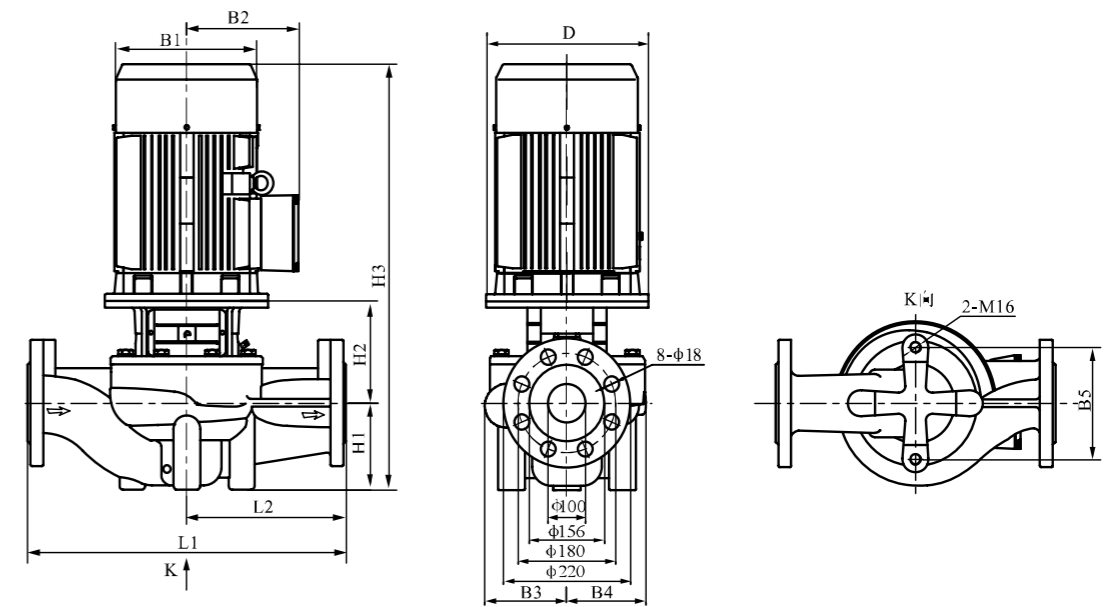

Size and weight

Model (2900rpm)	Size (mm)											Weight (kg)
	D	B1	B2	B3	B4	B5	H1	H2	H3	L1	L2	
TF, TX 100-50-9	140	171	137	134	101	160	105	178	570	450	225	56
TF, TX 100-60-15	160	214	169	134	101	160	105	190	637	450	225	73
TF, TX 100-80-17	200	257	190	146	118	144	120	199	702	450	225	96
TF, TX 100-78-22	200	257	190	146	118	144	120	199	702	450	225	104
TF, TX 100-100-27	350	314	261	147	123	144	140	260	900	550	275	187
TF, TX 100-100-33	350	314	261	147	123	144	140	260	900	550	275	202
TF, TX 100-100-40	350	314	261	181	152	230	140	270	954	550	275	220
TF, TX 100-100-48	350	355	273	181	152	230	140	270	987	550	275	273
TF, TX 100-130-52	400	397	314	181	152	230	140	270	1062	550	275	336

TF, TX 125 50Hz

Performance curve ISO9906:2012, 3B

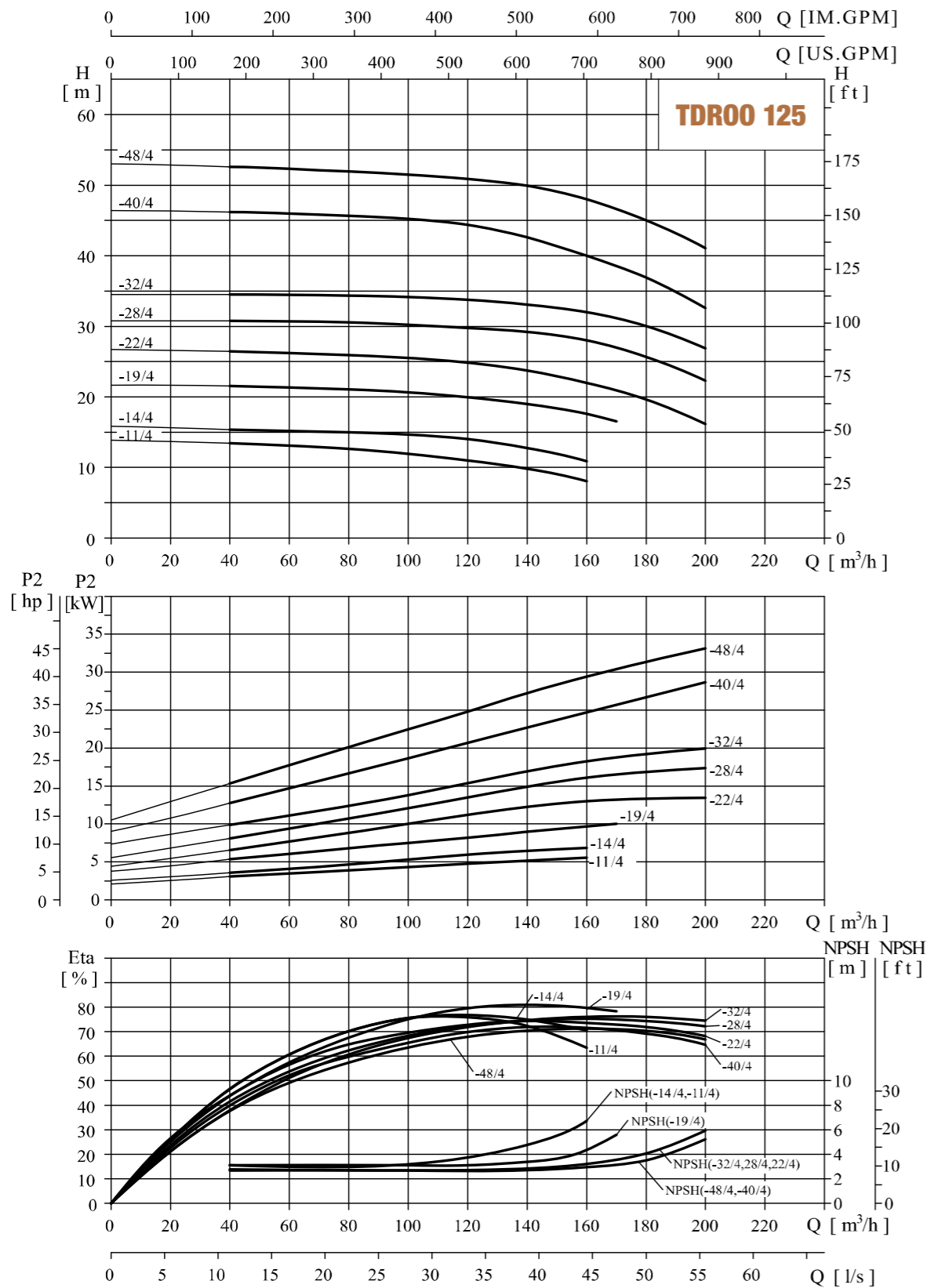

Performance table

Model (1450rpm)	Driving motor (kW)		Q (m³/h)	40	60	80	100	120	140	160	170	180	200
	(kW)	(hp)											
TF, TX 125-120-11	5.5	7.5	H (m)	13.4	13.1	12.6	11.9	11	9.8	8.1			
TF, TX 125-120-14	7.5	10		15.4	15.2	15	14.7	14	12.8	10.9			
TF, TX 125-140-19	11	15		21.5	21.3	21.1	20.7	19.9	19	17.6	16.5		
TF, TX 125-160-22	15	20		26.7	26.5	26.2	25.7	24.9	23.7	22	20.9	19.8	16.7
TF, TX 125-160-28	18.5	25		30.9	30.8	30.7	30.5	30.1	29.3	28	26.9	25.8	22.2
TF, TX 125-160-32	22	30		34.6	34.6	34.5	34.4	34	33.3	32	31.1	30.2	27.3
TF, TX 125-160-40	30	40		46.2	46	45.7	45.2	44.3	42.5	40	38.5	36.9	32.5
TF, TX 125-160-48	37	50		52.6	52.3	51.9	51.5	50.9	49.9	48	46.6	45	41.1

Installation sketch

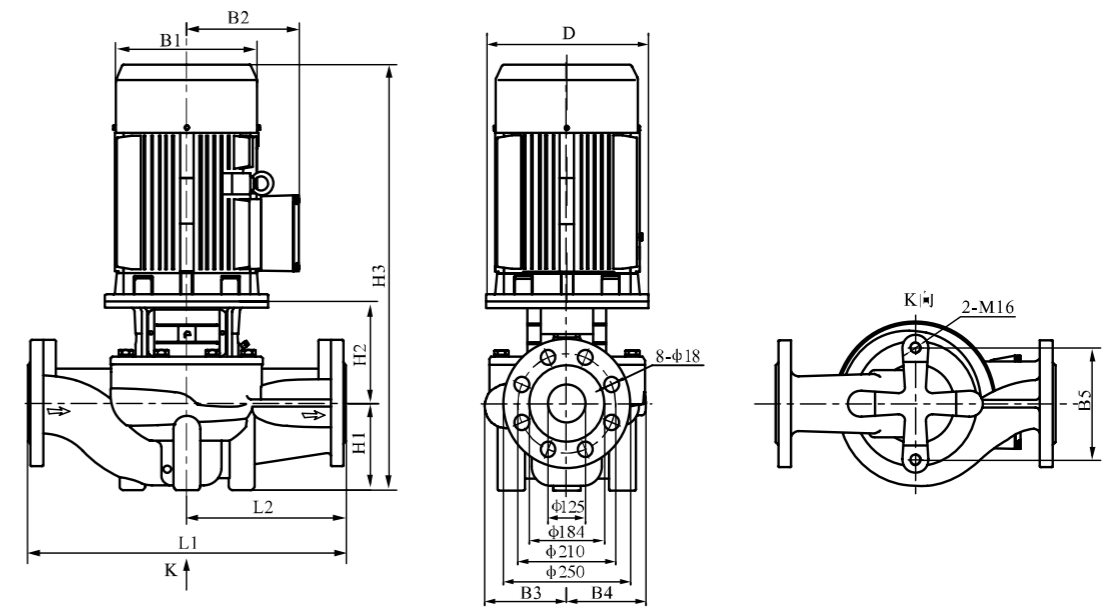

Size and weight

Model (1450rpm)	Size (mm)												Weight (kg)	
	D	B1	B2	B3	B4	B5	H1	H2	H2*	H3	H3*	L1		L2
TF, TX 125-120-11	200	257	190	198	162	230	160	229	—	772	—	620	310	140(—)
TF, TX 125-120-14	200	257	190	198	162	230	160	229	—	772	—	620	310	150(—)
TF, TX 125-140-19	350	314	261	213	178	230	160	301	401	961	1061	660	330	255(268)
TF, TX 125-160-22	350	314	261	236	208	230	215	292	395	1051	1154	800	400	310(323)
TF, TX 125-160-28	350	355	273	236	208	230	215	292	395	1084	1187	800	400	340(356)
TF, TX 125-160-32	350	355	273	236	208	230	215	292	395	1122	1125	800	400	361(376)
TF, TX 125-160-40	400	397	314	261	233	230	160	298	394	1110	1206	800	400	455(473)
TF, TX 125-160-48	400	445	334	261	233	230	160	313	440	1167	1294	800	400	492(521)

TF, TX 150 50Hz

Performance curve ISO9906:2012, 3B

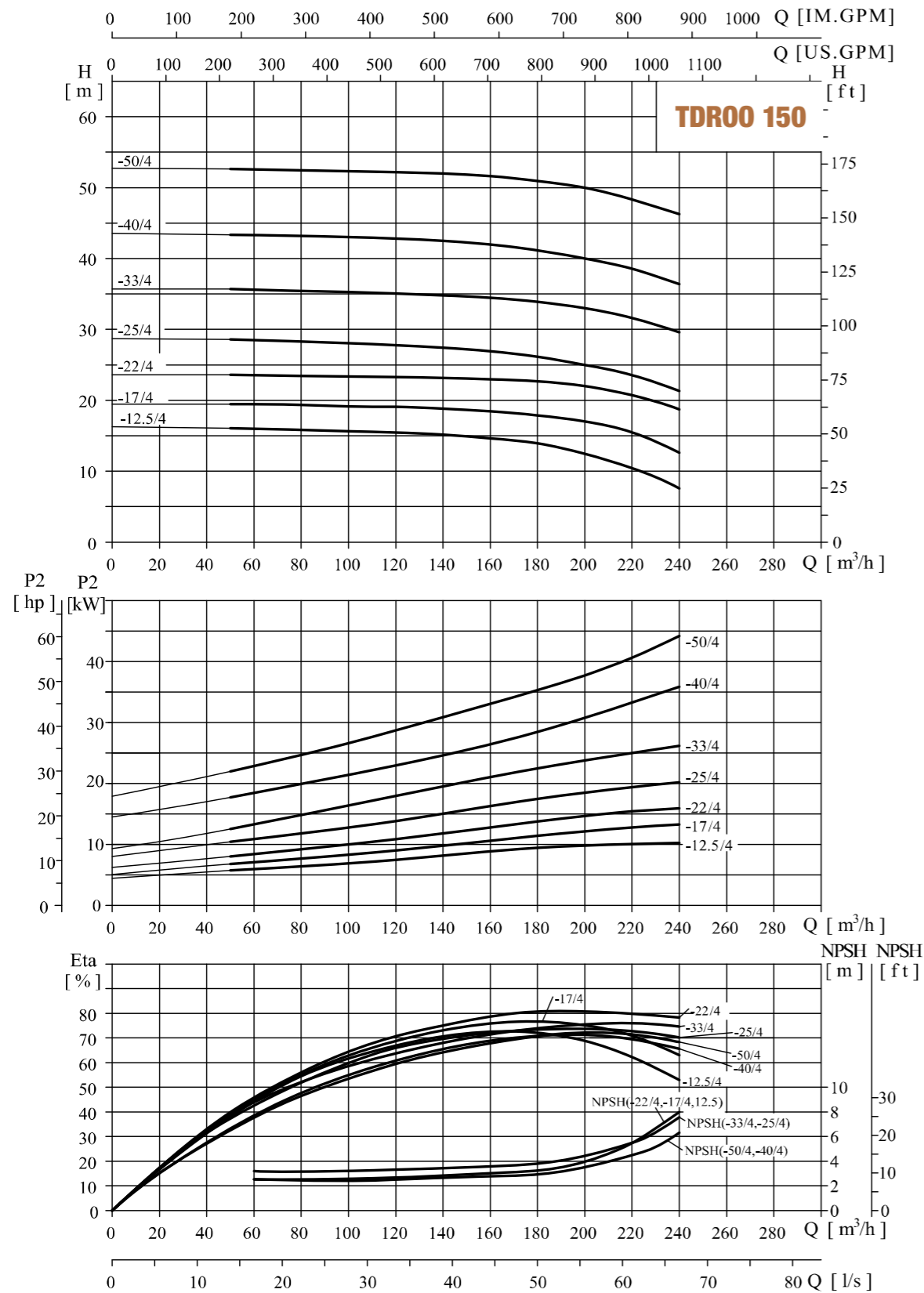

Performance table

Model (1450rpm)	Driving motor (kW)		Q (m³/h)	50	80	100	120	140	160	180	200	220	240
	(kW)	(hp)											
TF, TX 150-200-12.5	11	15	H (m)	16.1	15.8	15.6	15.4	15.1	14.6	13.9	12.5	10.4	7.6
TF, TX 150-200-17	15	20		19.5	19.4	19.2	19.1	18.8	18.4	17.9	17	15.5	12.6
TF, TX 150-200-22	18.5	25		23.6	23.4	23.4	23.3	23.1	23	22.7	22	20.7	18.7
TF, TX 150-200-25	22	30		28.1	28	27.9	27.7	27.3	26.8	26.1	25	23.5	21.3
TF, TX 150-200-33	30	40		35.5	35.4	35.3	35.1	34.8	34.4	33.9	33	31.5	29.6
TF, TX 150-200-40	37	50		43.1	43	42.9	42.7	42.4	41.9	41.1	40	38.4	36.2
TF, TX 150-200-50	45	60		52.4	52.2	52.1	51.9	51.7	51.4	50.9	50	48.7	46.7

Installation sketch

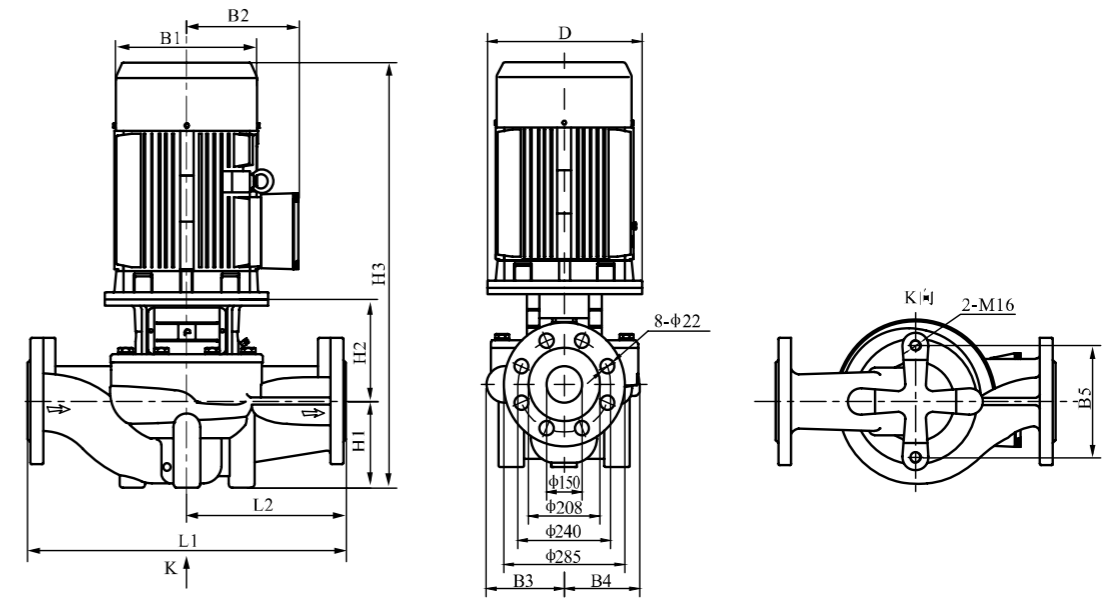

Size and weight

Model (1450rpm)	Size (mm)												Weight (kg)	
	D	B1	B2	B3	B4	B5	H1	H2	H2*	H3	H3*	L1		L2
TF, TX 150-200-12.5	350	314	261	217	180	230	175	297	397	972	1072	660	330	260(274)
TF, TX 150-200-17	350	314	261	217	180	230	175	297	397	1016	1116	660	330	281(295)
TF, TX 150-200-22	350	355	273	217	180	230	175	297	397	1049	1149	660	330	312(323)
TF, TX 150-200-25	350	355	273	238	208	230	215	269	372	1061	1164	800	400	365(384)
TF, TX 150-200-33	400	397	314	238	208	230	215	269	385	1136	1252	800	400	445(465)
TF, TX 150-200-40	450	445	334	267	248	230	230	288	416	1212	1340	900	450	518(544)
TF, TX 150-200-50	450	445	334	267	248	230	230	288	416	1212	1340	900	450	570(595)

Attention: The size with * in the data is Easy-disassembled inline-pump size. The weight in the braces is the weight of Easy-disassembled in-line pump.

TF, TX 200 50Hz

Performance curve ISO9906:2012, 3B

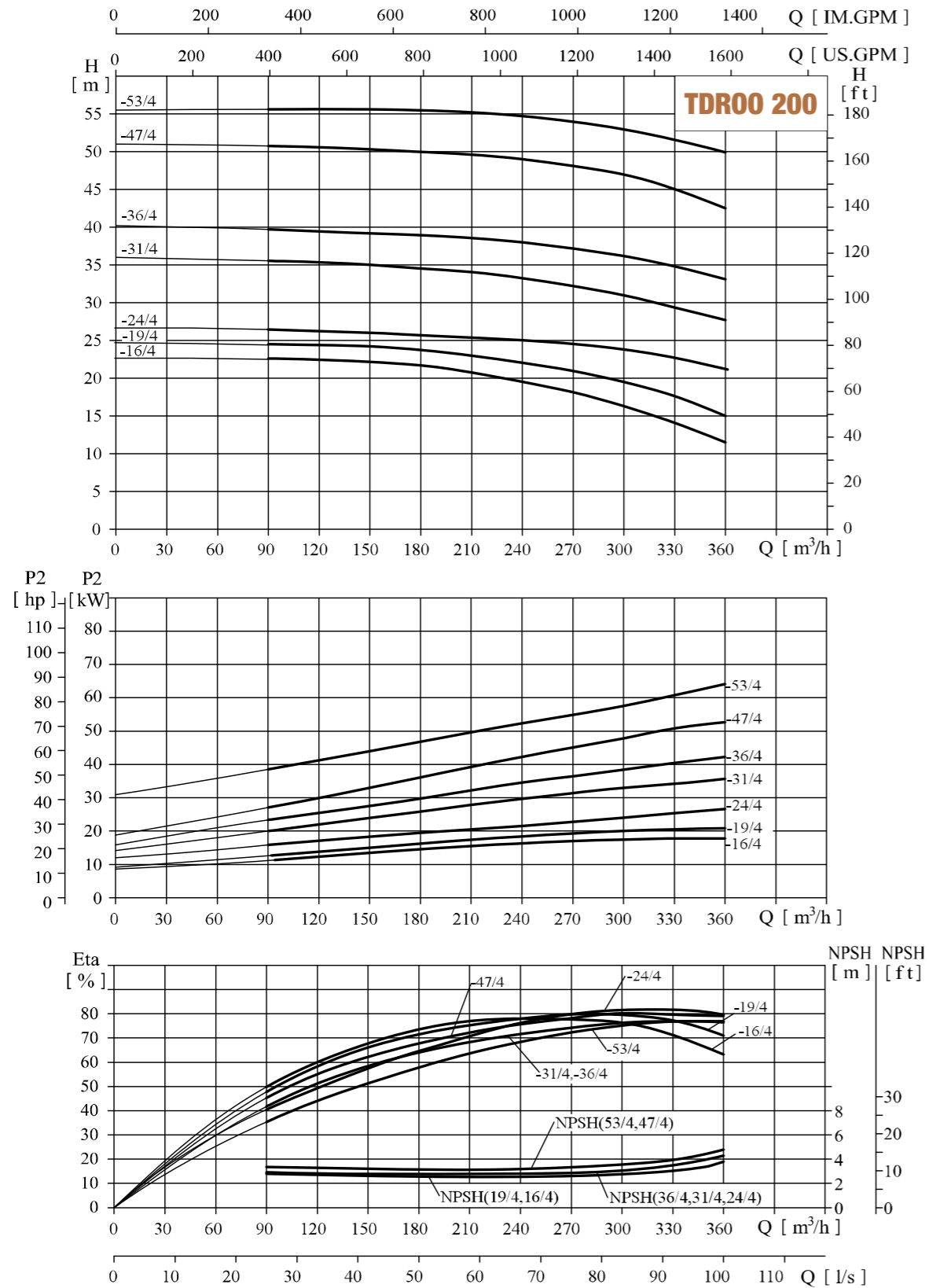

Performance table

Model (1450rpm)	Driving motor (kW)		Q (m³/h)	90	120	150	180	210	240	270	300	330	360
	(kW)	(hp)											
TF, TX 200-300-16	18,5	15	H (m)	22,6	22,4	22,2	21,7	20,7	19,4	18,1	16	14	11,5
TF, TX 200-300-19	22	20		24,4	24,3	24,2	23,7	23	22	20,9	19	17,6	15
TF, TX 200-300-24	30	25		26,1	26	25,8	25,7	25,4	25,1	24,6	24	23,1	21,5
TF, TX 200-300-31	37	30		35,4	35,3	35	34,5	33,9	33,2	32,2	31	29,3	27,6
TF, TX 200-300-36	45	40		39,6	39,4	39,1	38,8	38,5	37,9	37	36	34,7	33
TF, TX 200-300-47	55	50		50,6	50,5	50,2	49,8	49,5	48,9	48	47	44,9	42,4
TF, TX 200-300-53	75	60		55,7	55,7	55,7	55,5	55,3	54,8	54	53	51,6	50

Installation sketch

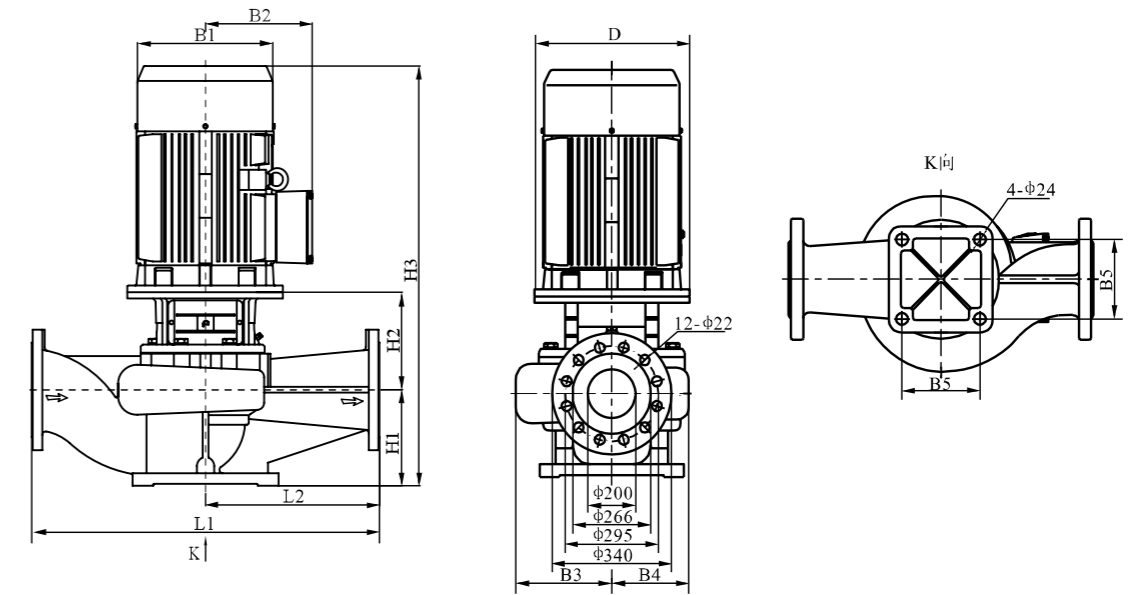

Size and weight

Model (1450rpm)	Size (mm)											Weight (kg)
	D	B1	B2	B3	B4	B5	H1	H2	H3	L1	L2	
TF, TX 200-300-16	350	355	273	278	219	360	270	415	1265	1000	500	417
TF, TX 200-300-19	350	355	273	278	219	360	270	415	1305	1000	500	434
TF, TX 200-300-24	400	397	314	303	252	360	270	415	1335	1100	550	537
TF, TX 200-300-31	450	445	334	303	252	360	270	445	1395	1100	550	602
TF, TX 200-300-36	450	445	334	303	252	360	270	445	1420	1100	550	648
TF, TX 200-300-47	550	484	367	315	269	360	270	457	1517	1100	550	744
TF, TX 200-300-53	550	547	407	315	269	360	270	457	1587	1100	550	877

TF, TX 200 50Hz

Performance curve ISO9906:2012, 3B

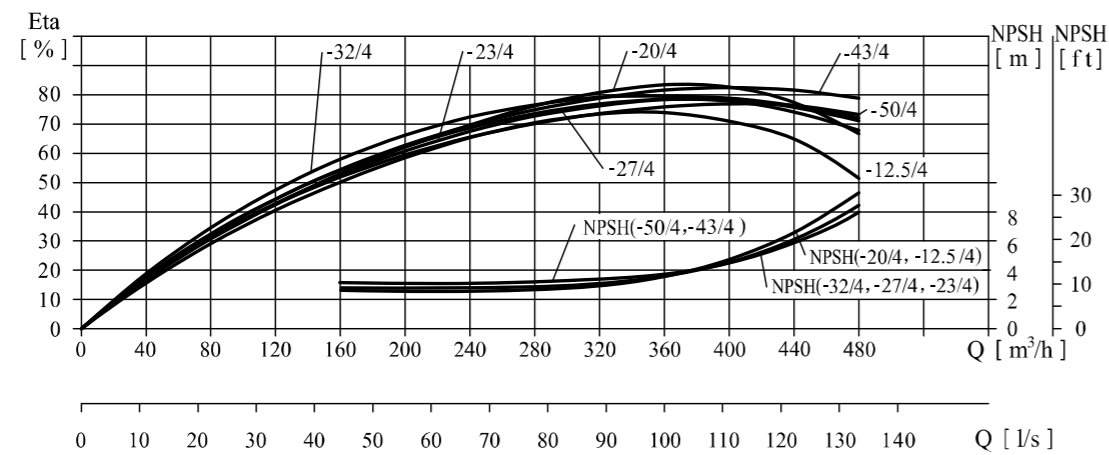
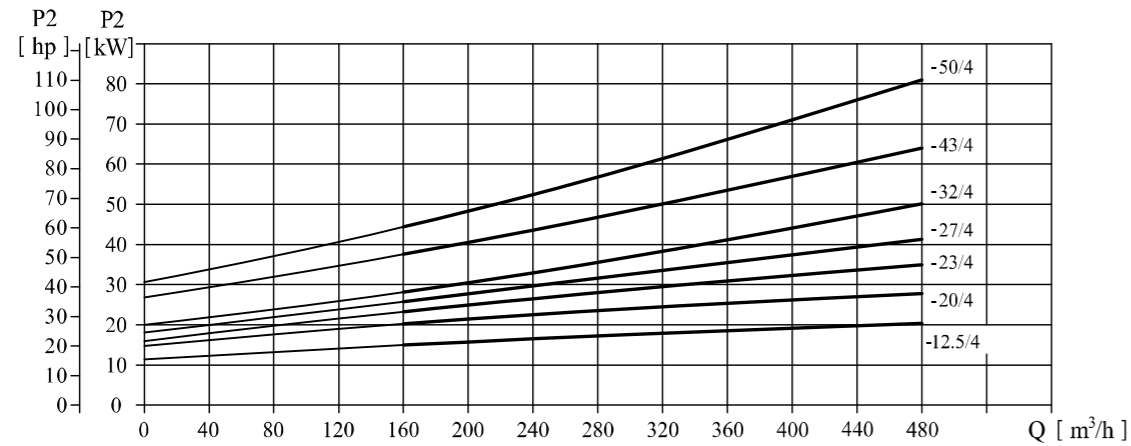
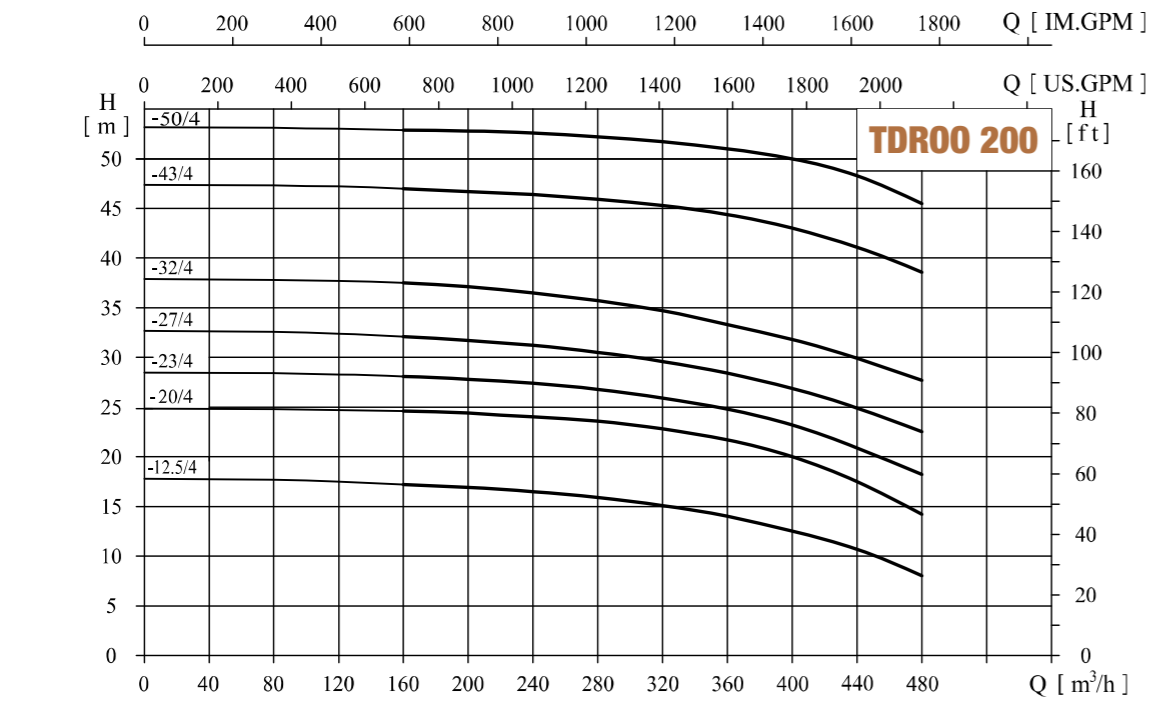

Performance table

Model (1450rpm)	Driving motor (kW)		Q (m³/h)	160	200	240	280	320	360	400	440	480
	(kW)	(hp)										
TF, TX 200-400-12.5	22	30	H (m)	17.2	16.9	16.5	15.9	15.1	14	12.5	10.7	8
TF, TX 200-400-20	30	40		24.6	24.4	24	23.6	22.8	21.7	20	17.5	14.2
TF, TX 200-400-23	37	50		28.1	27.8	27.4	26.8	25.9	24.8	23	20.9	18.2
TF, TX 200-400-27	45	60		32.1	31.7	31.2	30.5	29.6	28.4	27	24.9	22.5
TF, TX 200-400-32	55	75		37.5	37.1	36.5	35.7	34.7	33.3	32	29.9	27.7
TF, TX 200-400-43	75	100		47	46.7	46.4	45.9	45.3	44.4	43	41.1	38.6
TF, TX 200-400-50	90	120		52.9	52.8	52.6	52.2	51.7	51	50	48.3	45.5

Installation sketch

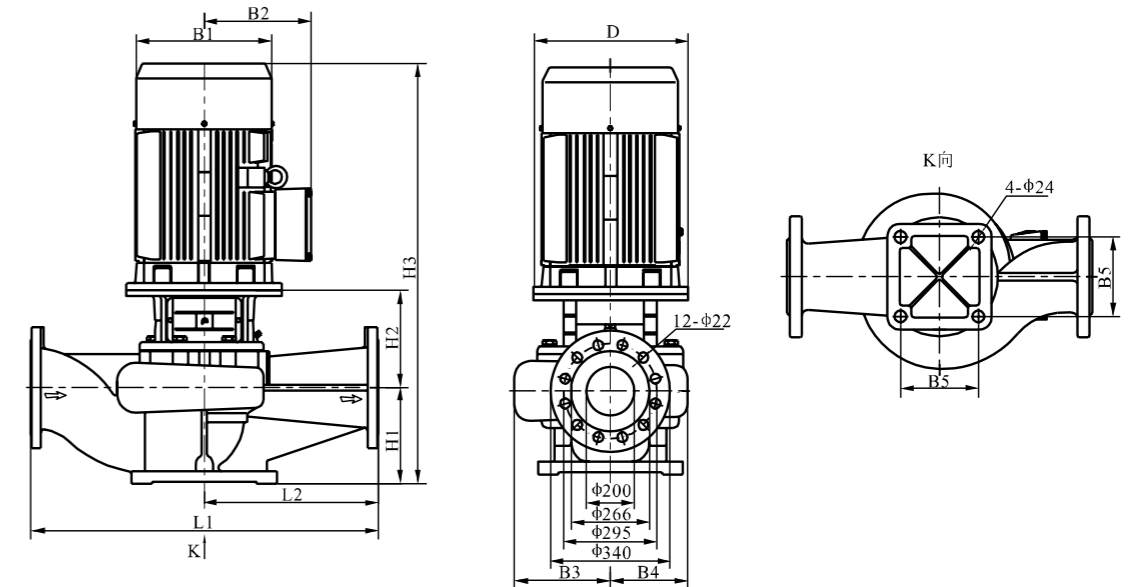

Size and weight

Model (1450rpm)	Size (mm)											Weight (kg)
	D	B1	B2	B3	B4	B5	H1	H2	H3	L1	L2	
TF, TX 200-400-12.5	350	355	273	278	219	360	270	415	1300	1000	500	432
TF, TX 200-400-20	400	397	314	278	219	360	270	415	1334	1000	500	492
TF, TX 200-400-23	450	445	334	303	252	360	270	445	1389	1100	550	602
TF, TX 200-400-27	450	445	334	303	252	360	270	445	1412	1100	550	638
TF, TX 200-400-32	550	484	367	303	252	360	270	445	1488	1100	550	710
TF, TX 200-400-43	550	547	407	315	269	360	270	457	1556	1100	550	883
TF, TX 200-400-50	550	547	407	315	269	360	270	457	1607	1100	550	975

TF, TX 250 50Hz

Performance curve ISO9906:2012, 3B

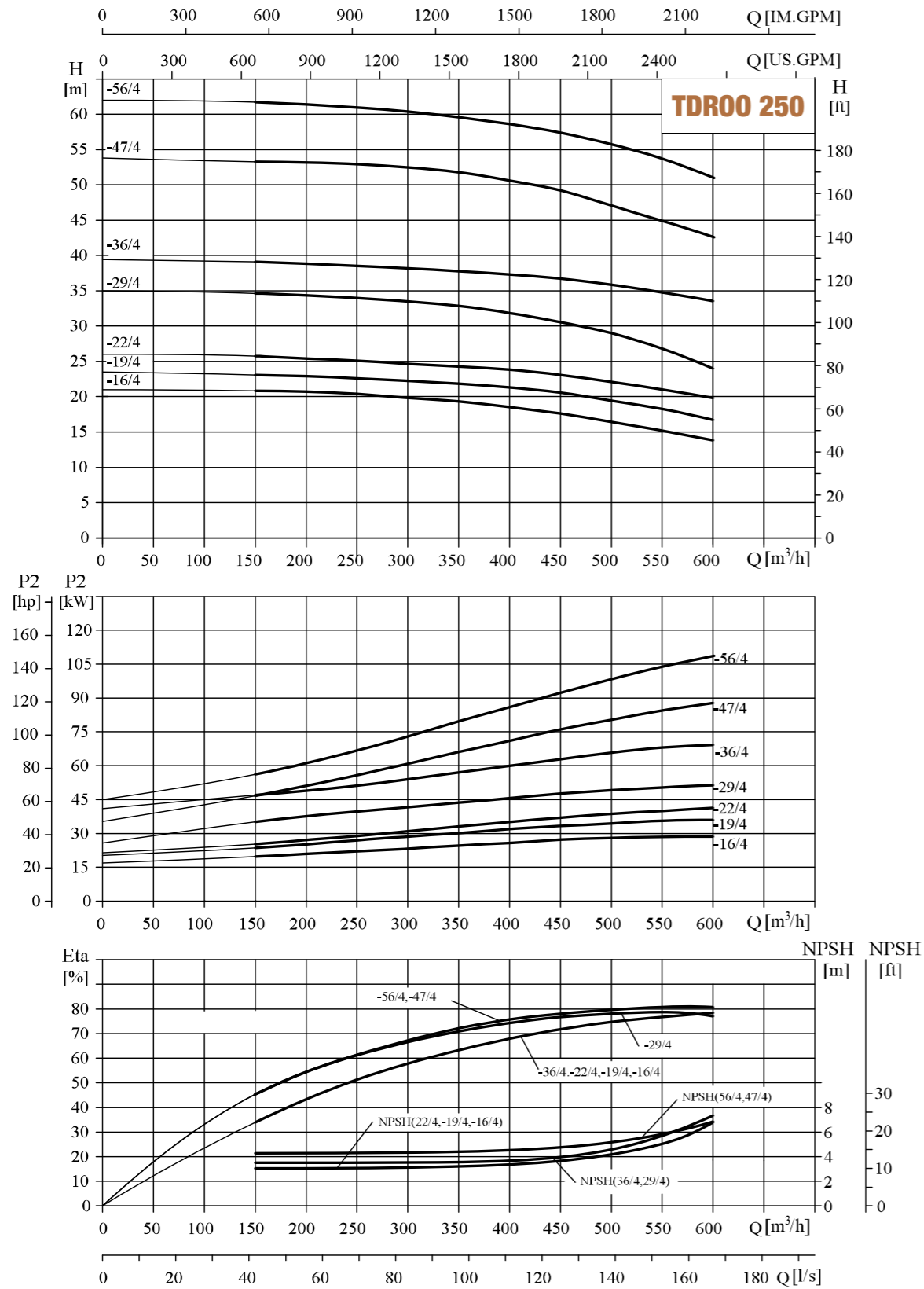

Performance table

Model (1450rpm)	Driving motor (kW)		Q (m³/h)	150	200	250	300	350	400	450	500	550	600
	(kW)	(hp)											
TF, TX 250-500-16	30	40	H (m)	20.5	20.4	20.1	19.6	19	18.2	17.3	16	14.7	13.3
TF, TX 250-500-19	37	50		22.7	22.4	22.1	21.7	21.3	20.8	20.1	19	17.9	16.6
TF, TX 250-500-22	45	60		25.7	25.3	25.1	24.7	24.3	23.8	23.1	22	21	19.7
TF, TX 250-500-29	55	75		34.6	34.4	34	34.4	32.6	31.8	30.6	29	26.8	23.9
TF, TX 250-500-36	75	100		39.1	38.8	38.5	38.2	37.8	37.3	36.8	36	34.3	32.5
TF, TX 250-500-47	90	120		53.3	53.1	52.9	52.4	51.8	50.6	49.2	47	45	42.5
TF, TX 250-500-56	110	150		61.6	61.4	60.9	60.2	59.5	58.6	57.4	56	53.8	51

Installation sketch

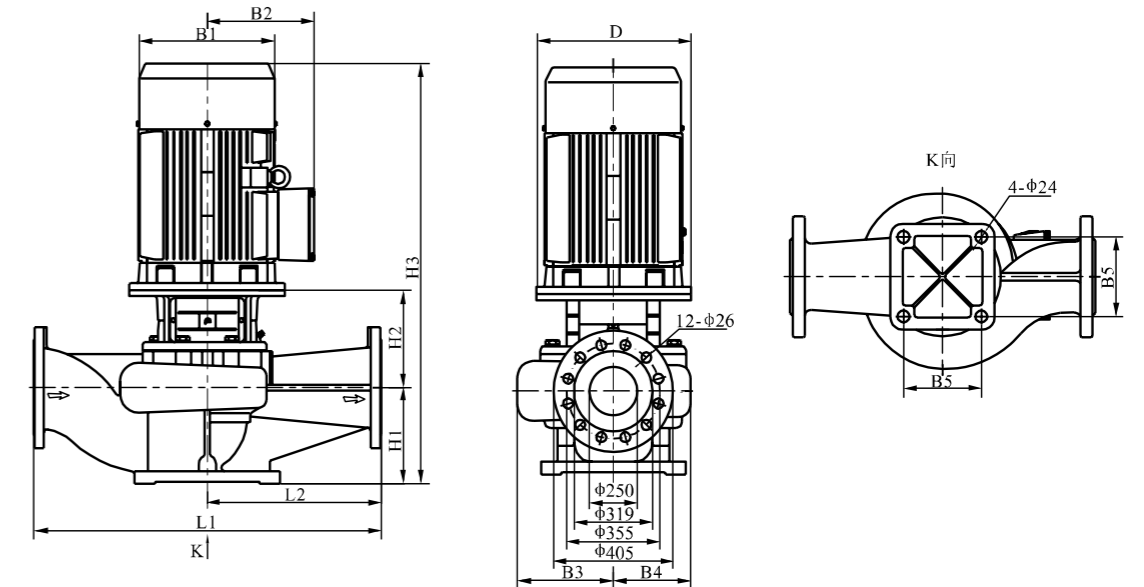

Size and weight

Model (1450rpm)	Size (mm)											Weight (kg)
	D	B1	B2	B3	B4	B5	H1	H2	H3	L1	L2	
TF, TX 250-500-16	400	397	314	316	243	390	300	465	1430	1100	550	550
TF, TX 250-500-19	450	445	334	316	243	390	300	495	1475	1100	550	611
TF, TX 250-500-22	450	445	334	316	243	390	300	495	1500	1100	550	647
TF, TX 250-500-29	550	484	367	329	264	440	300	507	1597	1100	550	773
TF, TX 250-500-36	550	547	407	329	264	440	300	507	1667	1100	550	909
TF, TX 250-500-47	550	547	407	347	292	440	305	485	1700	1200	600	1030
TF, TX 250-500-56	660	645	535	347	292	440	305	525	1860	1200	600	1389

TF, TX 250 50Hz

Performance curve ISO9906:2012, 3B

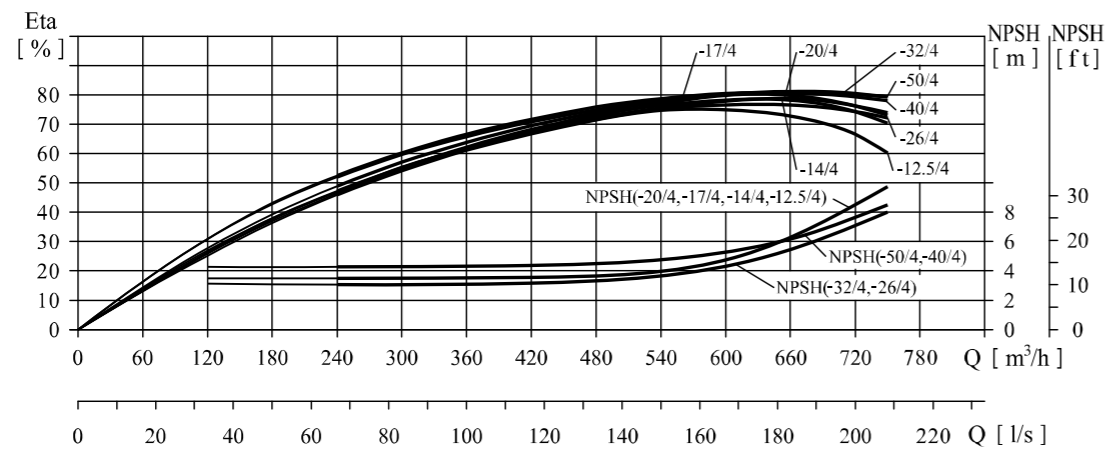
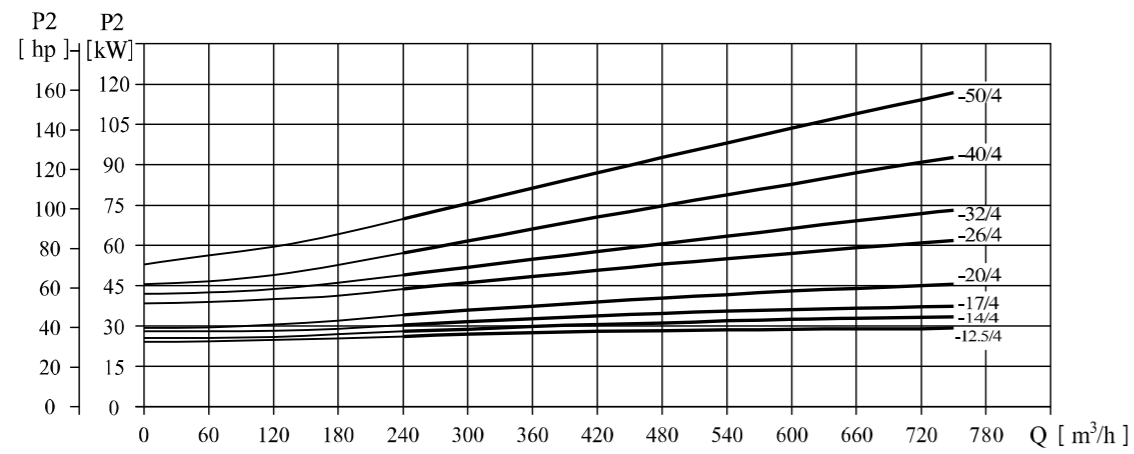
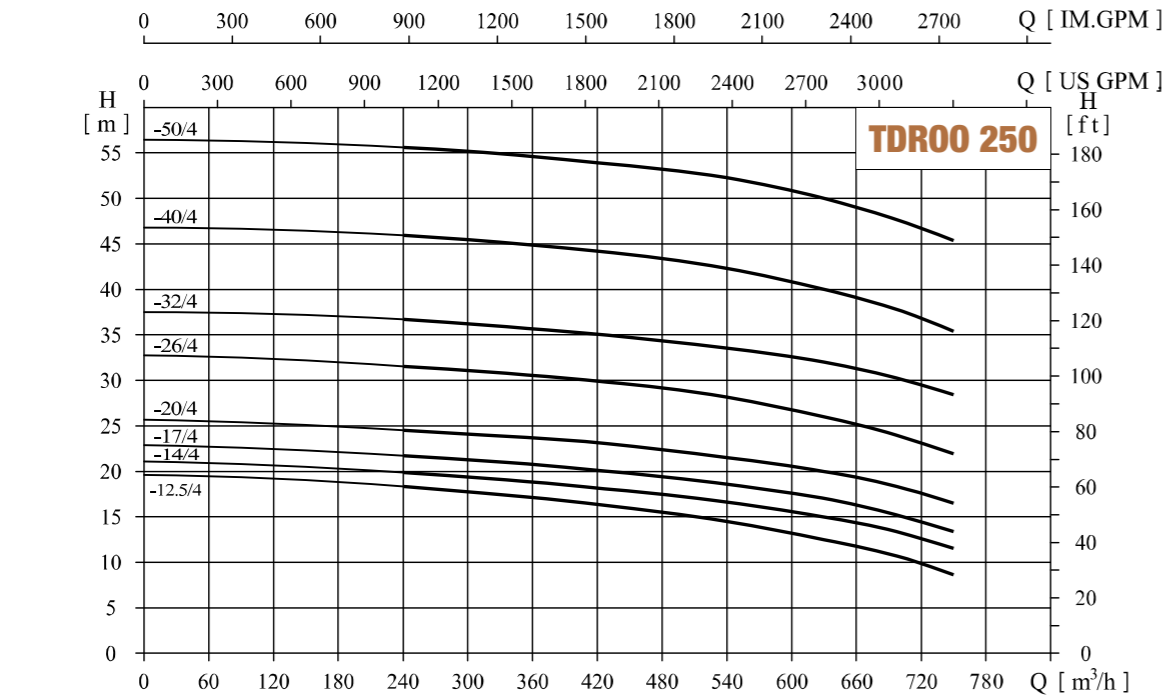

Performance table

Model (1450rpm)	Driving motor (kW)		Q (m³/h)	240	300	360	420	480	540	600	630	660	720	750
	(kW)	(hp)												
TF, TX 250-630-12.5	30	40	H (m)	18.4	17.9	17.2	16.4	15.5	14.5	13.2	12.5	11.8	9.9	8.7
TF, TX 250-630-14	37	50		20	19.5	18.9	18.2	17.5	16.6	15.6	14	13.4	12.6	11.6
TF, TX 250-630-17	45	60		21.8	21.3	20.8	20.1	19.4	18.6	17.6	17	16.3	14.4	13.4
TF, TX 250-630-20	55	75		24.5	24.1	23.7	23.1	22.4	21.5	20.5	20	19.3	17.6	16.5
TF, TX 250-630-26	75	100		31.7	31.1	30.6	29.9	29.1	28.2	26.8	26	25.2	23.1	21.9
TF, TX 250-630-32	90	120		36.7	36.3	35.7	35.1	34.3	33.5	32.6	32	31.3	29.5	28.4
TF, TX 250-630-40	110	150		46	45.5	44.9	44.2	43.4	42.3	40.8	40	39.1	36.8	35.5
TF, TX 250-630-50	132	180		55.6	55.2	54.6	53.9	53.2	52.3	50.9	50	49	46.7	45.4

Installation sketch

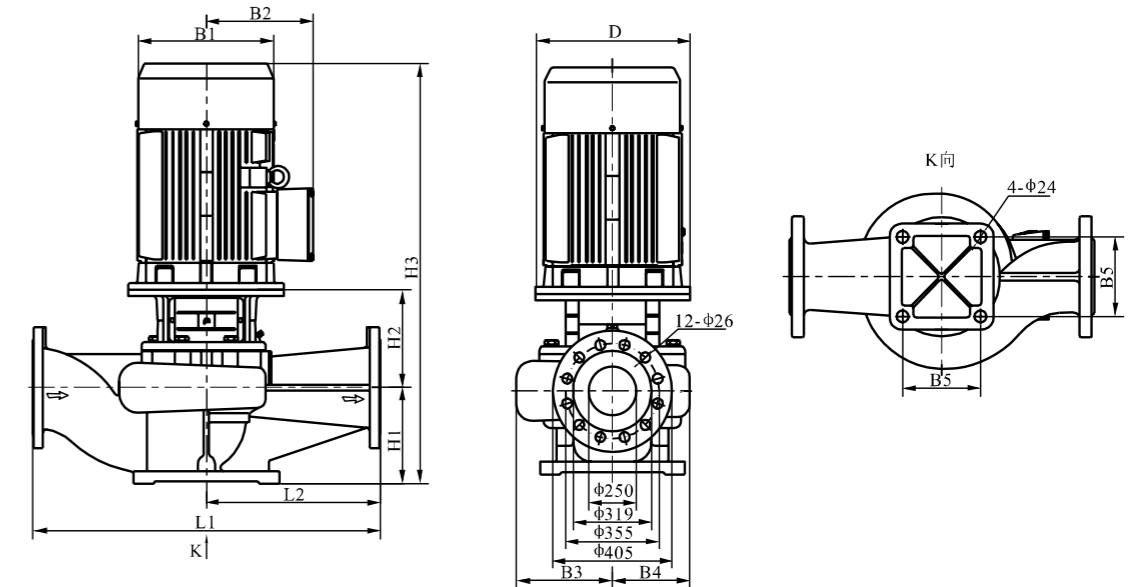

Size and weight

Model (1450rpm)	Size (mm)											Weight (kg)
	D	B1	B2	B3	B4	B5	H1	H2	H3	L1	L2	
TF, TX 250-630-12.5	400	397	314	316	243	390	300	465	1414	1100	550	552
TF, TX 250-630-14	450	445	334	316	243	390	300	495	1469	1100	550	613
TF, TX 250-630-17	450	445	334	316	243	390	300	495	1492	1100	550	649
TF, TX 250-630-20	550	484	367	316	243	390	300	495	1568	1100	550	722
TF, TX 250-630-26	550	547	407	329	264	440	300	507	1636	1100	550	909
TF, TX 250-630-32	550	547	407	329	264	440	300	507	1687	1100	550	999
TF, TX 250-630-40	660	645	535	347	292	440	305	525	1840	1200	600	1389
TF, TX 250-630-50	660	645	535	347	292	440	305	525	1990	1200	600	1473

TF, TX 300 50Hz

Performance curve ISO9906:2012, 3B

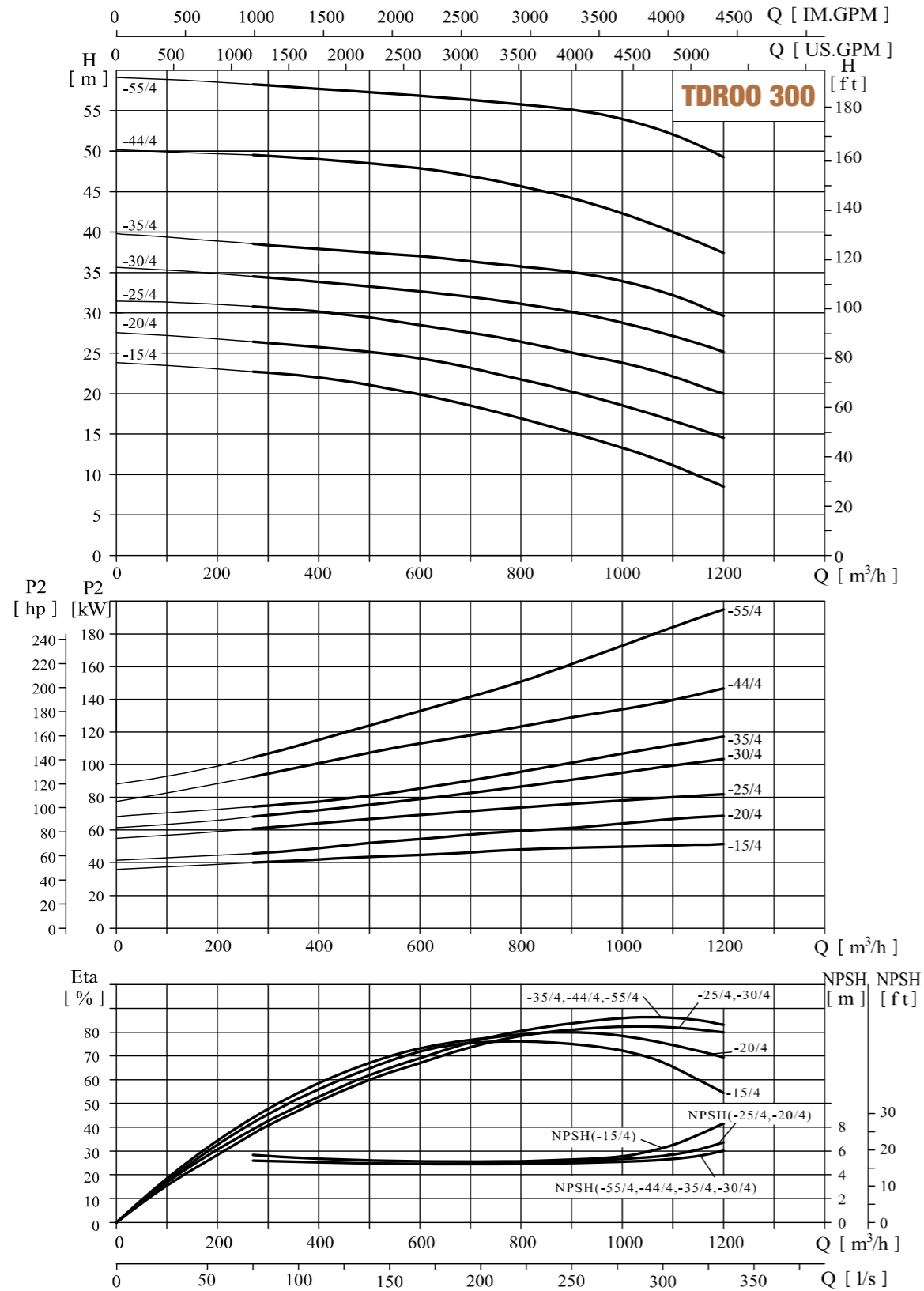

Performance table

Model (1450rpm)	Driving motor (kW)		Q (m³/h)	270	360	450	630	750	900	1080	1200
	(kW)	(hp)									
TF, TX 300-900-15	55	75	H (m)	22.7	22.3	21.6	19.5	17.8	15	11.6	8.5
TF, TX 300-900-20	75	100		26.4	26	25.5	24.1	22.4	20	17.1	14.5
TF, TX 300-900-25	90	120		30.8	30.4	29.8	28.2	27.1	25	22.5	20
TF, TX 300-900-30	110	150		34.5	34	33.5	32.4	31.6	30	27.5	25
TF, TX 300-900-35	132	180		38.6	38.1	37.8	36.9	36	35	32.6	29.6
TF, TX 300-900-44	160	215		49.5	49.2	48.8	47.6	46.3	44	40.5	37.5
TF, TX 300-900-55	200	270		58.2	57.9	57.6	56.7	56.1	55	52.5	49.2

Installation sketch

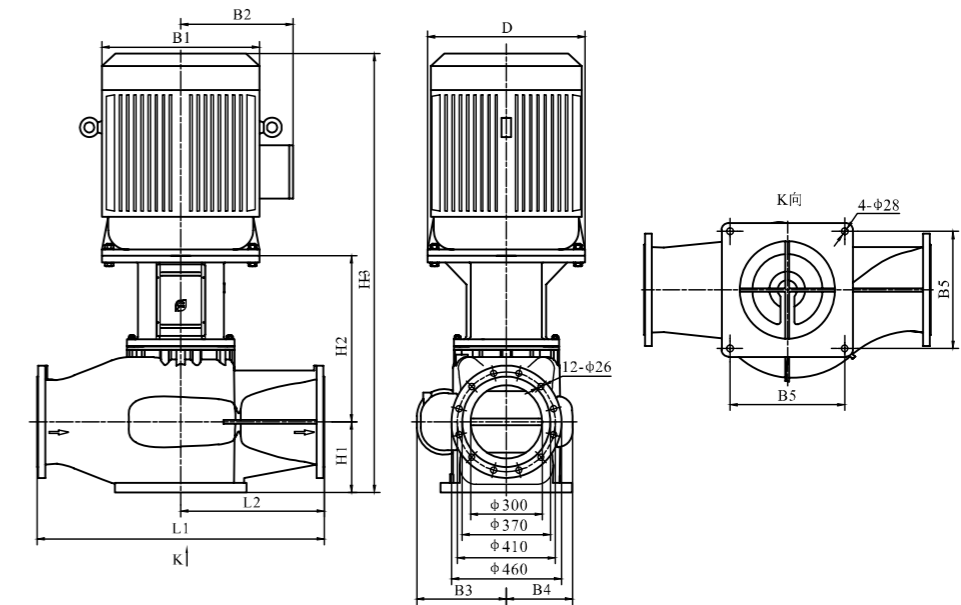

Size and weight

Model (1450rpm)	Size (mm)											Weight (kg)
	D	B1	B2	B3	B4	B5	H1	H2	H3	L1	L2	
TF, TX 300-900-15	550	484	367	345	250	440	290	649	1720	1200	600	907
TF, TX 300-900-20	550	547	407	345	250	440	290	649	1770	1200	600	1075
TF, TX 300-900-25	550	547	407	380	280	480	290	659	1850	1200	600	1230
TF, TX 300-900-30	660	645	535	380	280	480	290	699	2000	1200	600	1570
TF, TX 300-900-35	660	645	535	380	280	480	290	699	2150	1200	600	1650
TF, TX 300-900-44	660	645	535	380	295	480	290	702	2150	1200	600	1790
TF, TX 300-900-55	660	645	535	380	295	480	290	702	2150	1200	600	1905

TF, TX 32 60Hz

Performance curve ISO9906:2012, 3B

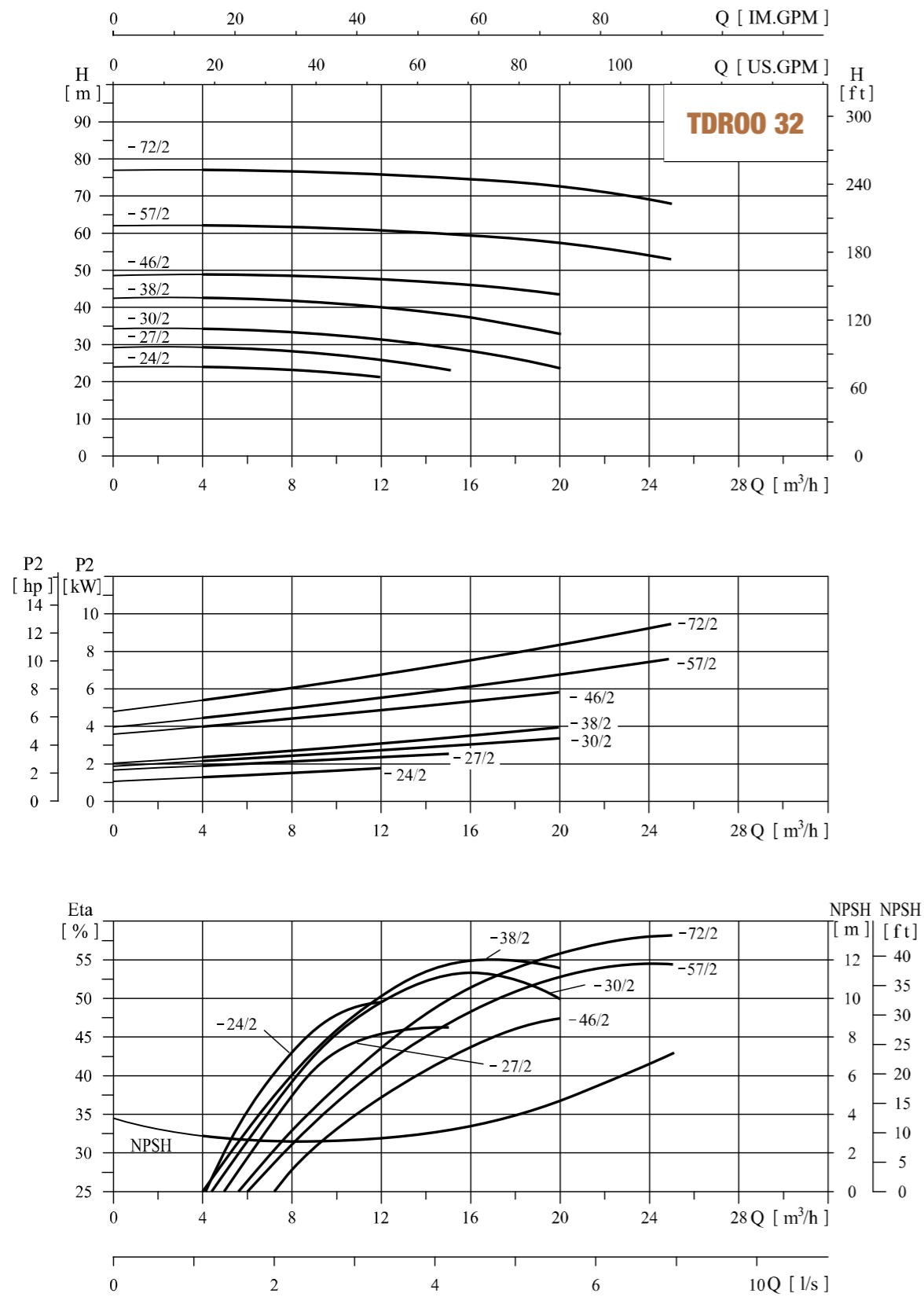

Performance table

Model (3500rpm)	Driving motor (kW)		Q (m³/h)	4	7	8	10	12	15	20	25
	(kW)	(hp)									
TF, TX 32-7-24	1.5	2	H (m)	24.5	24	23		21			
TF, TX 32-10-27	2.2	3		29		28	27	26	23		
TF, TX 32-15-30	3	4		35		34		32	30	23	
TF, TX 32-15-38	4	5.5		43		42		40	38	33	
TF, TX 32-15-46	5.5	7.5		49		49		48	46	44	
TF, TX 32-20-57	7.5	10		62		62		61	59	57	53
TF, TX 32-20-72	11	15		77		77		76	75	72	67

Installation sketch

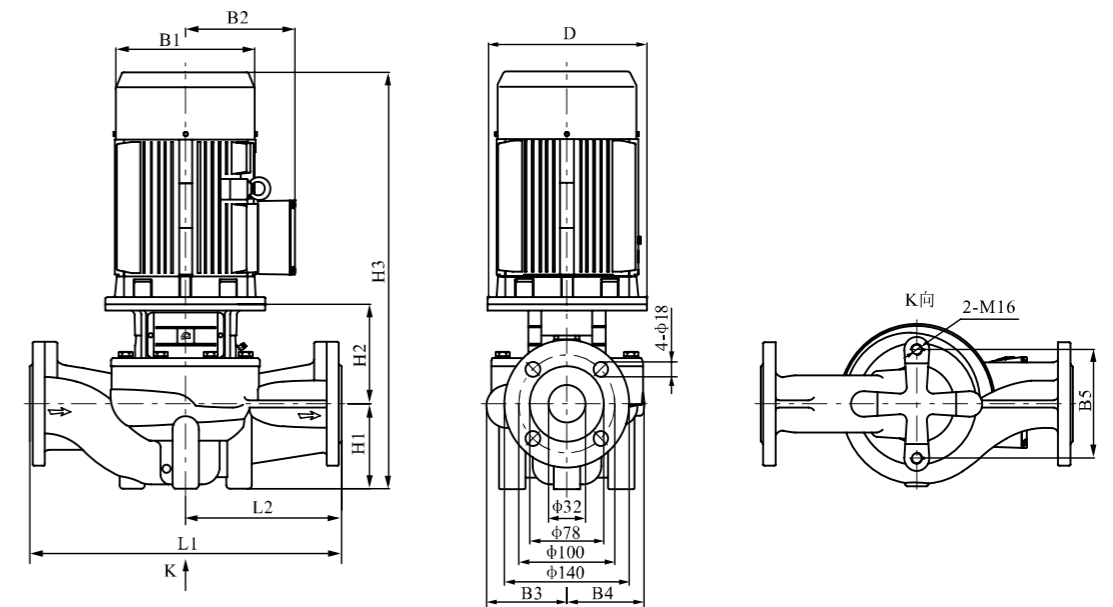

Size and weight

Model (3500rpm)	Size (mm)											Weight (kg)
	D	B1	B2	B3	B4	B5	H1	H2	H3	L1	L2	
TF, TX 32-7-24	140	190	155	115	115	144	100	166	556	340	170	56
TF, TX 32-10-27	140	190	155	115	115	144	100	166	556	340	170	59
TF, TX 32-15-30	160	197	165	115	115	144	100	185	630	340	170	68
TF, TX 32-15-38	160	230	188	129	129	144	100	185	640	440	220	79
TF, TX 32-15-46	200	260	208	129	129	144	100	213	703	440	220	104
TF, TX 32-20-57	200	260	208	129	129	144	100	213	703	440	220	107
TF, TX 32-20-72	350	330	255	129	129	144	100	262	862	440	220	167

TF, TX 40 60Hz

Performance curve ISO9906:2012, 3B

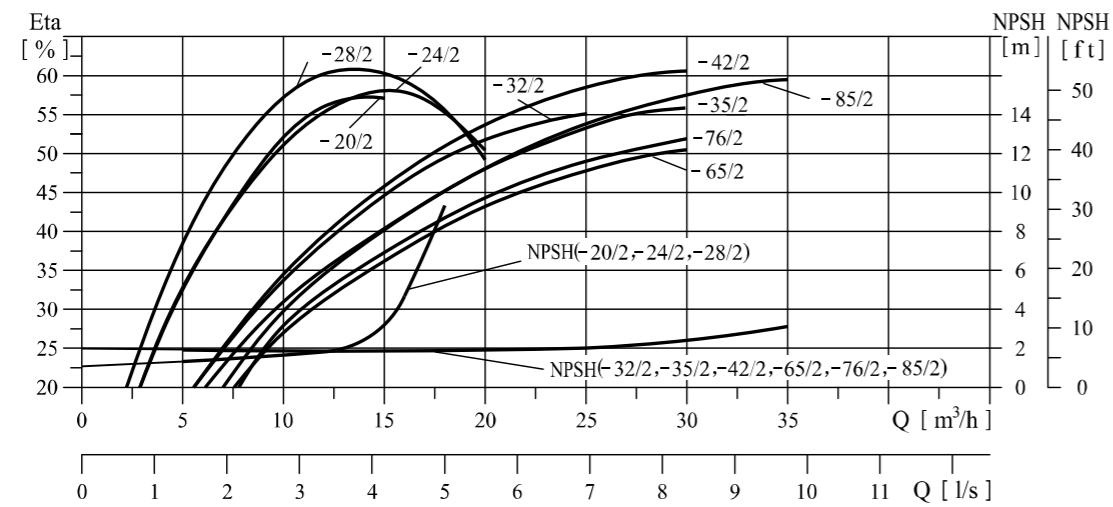
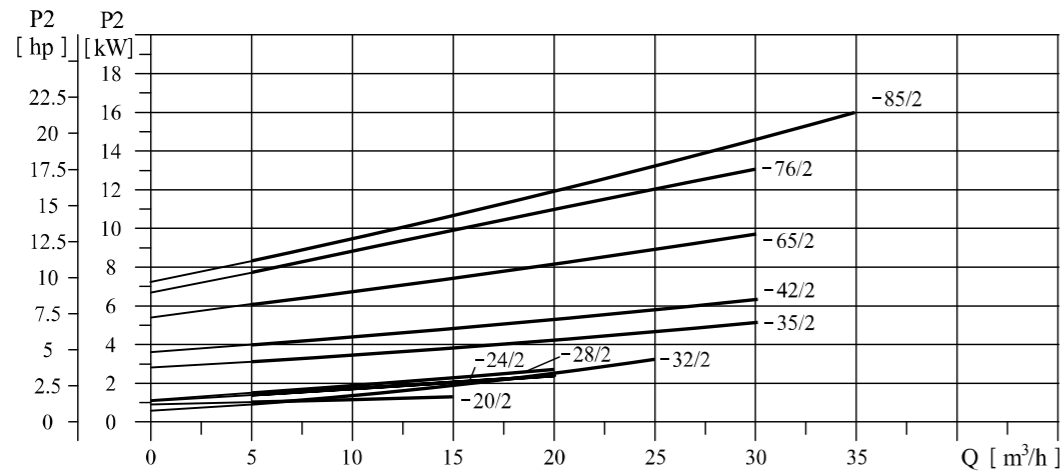
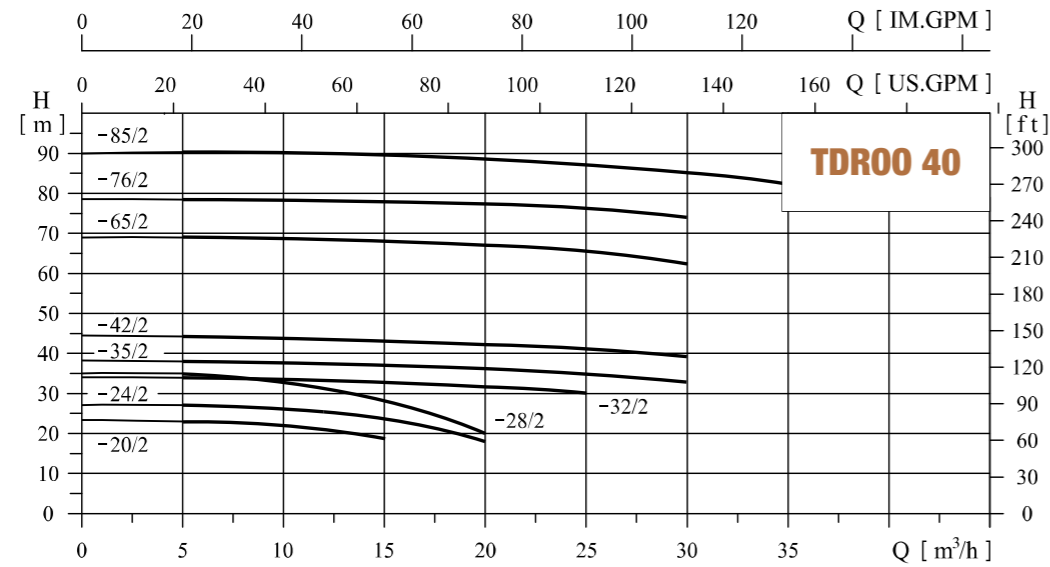

Performance table

Model (3500rpm)	Driving motor (kW)		Q (m³/h)	5	10	12	15	20	25	30	35
	(kW)	(hp)									
TF, TX 40-12-20	1.5	2	H (m)	23	22	20	18				
TF, TX 40-15-24	2.2	3		27	26		24	18			
TF, TX 40-15-28	3	4		35	33		28	20			
TF, TX 40-20-32	4	5.5		34	34		33	32	30		
TF, TX 40-25-35	5.5	7.5		38	38		37	36	35	33	
TF, TX 40-25-42	7.5	10		45	45		44	43	42	40	
TF, TX 40-25-65	11	15		69	69		68	67	65	63	
TF, TX 40-25-76	15	20		79	79		78	77	76	73	
TF, TX 40-30-85	18.5	25		91	91		90	89	87	85	82

Installation sketch

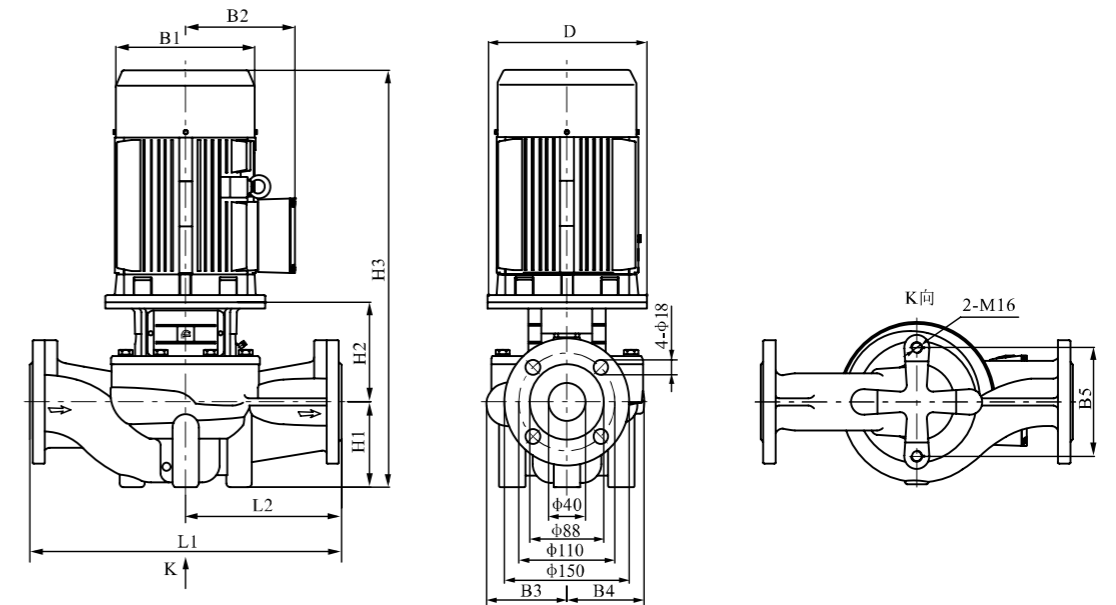

Size and weight

Model (3500rpm)	Size (mm)											Weight (kg)
	D	B1	B2	B3	B4	B5	H1	H2	H3	L1	L2	
TF, TX 40-12-20	140	190	155	97	95	120	68	160	518	320	160	46
TF, TX 40-15-24	140	190	155	97	95	120	68	160	518	320	160	53
TF, TX 40-15-28	160	197	165	97	95	120	68	178	591	320	160	70
TF, TX 40-20-32	160	230	188	138	128	144	110	185	650	440	220	77
TF, TX 40-25-35	200	260	208	138	128	144	110	213	713	440	220	106
TF, TX 40-25-42	200	260	208	138	128	144	110	213	713	440	220	110
TF, TX 40-25-65	350	330	255	138	128	144	110	262	872	440	220	167
TF, TX 40-25-76	350	330	255	140	138	144	110	262	872	440	220	178
TF, TX 40-30-85	350	330	255	140	138	144	110	262	922	440	220	196

TF, TX 50 60Hz

Performance curve ISO9906:2012, 3B

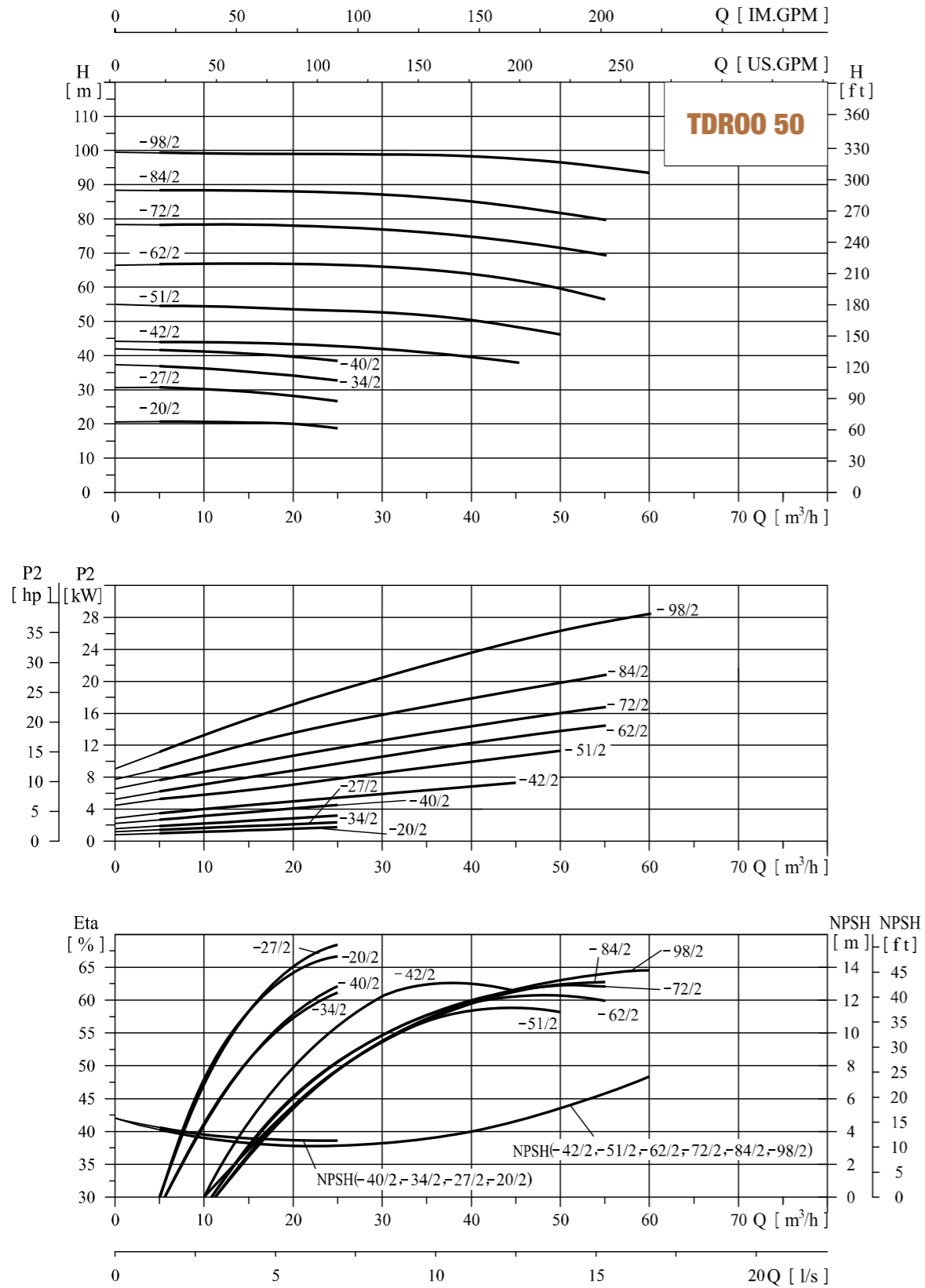

Performance table

Model (3500rpm)	Driving motor (kW)		Q (m³/h)	5	10	15	20	25	30	35	40	45	50	55	60
	(kW)	(hp)													
TF, TX 50-20-20	2.2	3		21	20.5	20.3	20	18.5							
TF, TX 50-20-27	3	4		31	30	28.8	27	26							
TF, TX 50-20-34	4	5.5		37	36.2	35.3	34	32.7							
TF, TX 50-20-40	5.5	7.5		41.5	41.2	41	40	39							
TF, TX 50-30-42	7.5	10		45.5	44		43		42		40	39			
TF, TX 50-35-51	11	15		54	53.5		52.5		52	51	50		47		
TF, TX 50-45-62	15	20		66.5	66.6		66		65		63	62	59	56	
TF, TX 50-45-72	18.5	25		77	77		77.2		76		73	72	71	69	
TF, TX 50-45-84	22	30		88	88		88		87		85	84	83	82	
TF, TX 50-50-98	30	40		99.1	99.4		99.6		99		98.5		98		93

Installation sketch

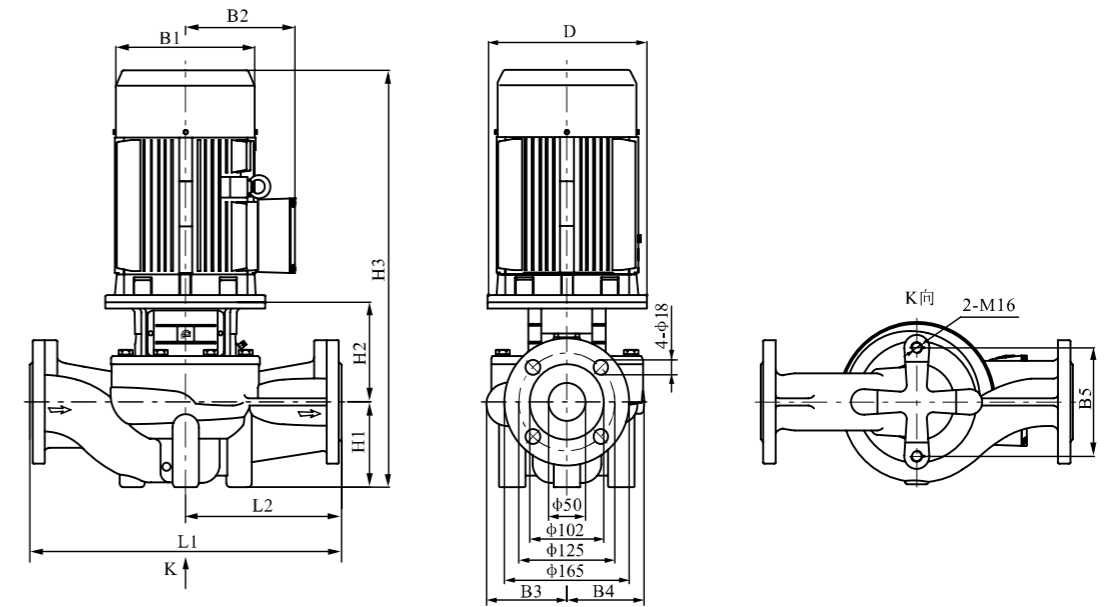

Size and weight

Model (3500rpm)	Size (mm)											Weight (kg)
	D	B1	B2	B3	B4	B5	H1	H2	H3	L1	L2	
TF, TX 50-20-20	140	190	155	117	115	144	115	153	558	340	170	65
TF, TX 50-20-27	160	197	165	117	115	144	115	172	632	340	170	74
TF, TX 50-20-34	160	230	188	129	115	144	115	172	642	340	170	79
TF, TX 50-20-40	200	260	208	129	115	144	115	197	702	340	170	103
TF, TX 50-30-42	200	260	208	171	158	144	115	197	702	440	220	118
TF, TX 50-35-51	350	330	255	171	158	144	115	250	865	440	220	151
TF, TX 50-45-62	350	330	255	171	158	144	115	250	865	440	220	191
TF, TX 50-45-72	350	330	255	171	158	144	115	250	915	440	220	209
TF, TX 50-45-84	350	360	285	171	158	144	115	250	940	440	220	245
TF, TX 50-50-98	400	400	310	171	158	144	115	250	1015	440	220	296

TF, TX 65 60Hz

Performance curve ISO9906:2012, 3B

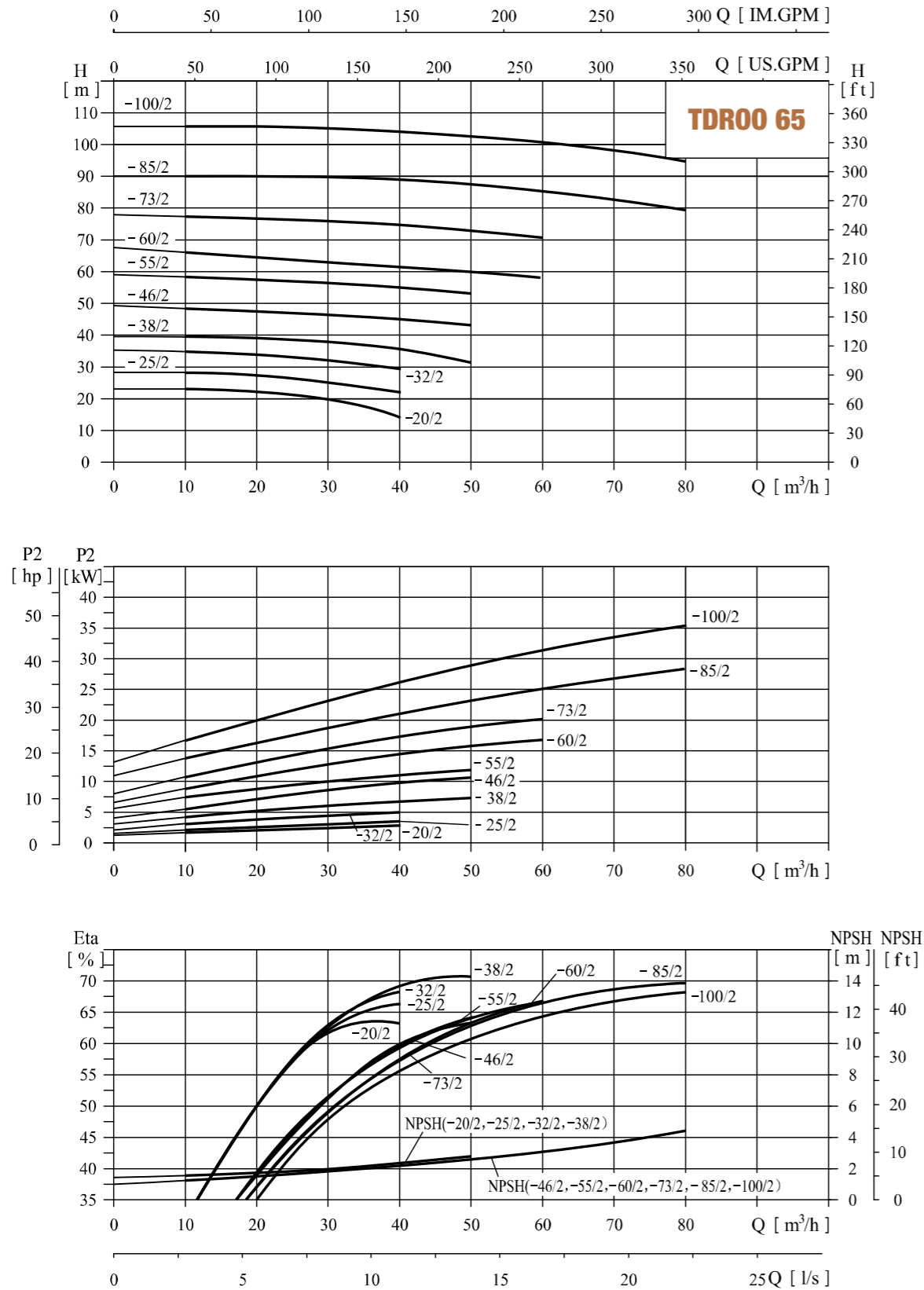

Performance table

Model (3500rpm)	Driving motor (kW)		Q (m³/h)	10	20	30	35	40	50	60	70	80
	(kW)	(hp)										
TF, TX 65-30-20	3	4	H (m)	22.2	22	20	18	14.3				
TF, TX 65-30-25	4	5.5		28	27	25	24	21				
TF, TX 65-30-32	5.5	7.5		35	33.5	32	31	29.5				
TF, TX 65-35-38	7.5	10		39.5	38.7	38.5	38	36	31.5			
TF, TX 65-35-46	11	15		48	47	46.5	46	45	44			
TF, TX 65-35-55	15	20		57.3	56.5	56.2	55	54	52			
TF, TX 65-50-60	18.5	25		64	63.8	62	61.8	60.5	60	56		
TF, TX 65-50-73	22	30		78	77	76.5	76	75.5	73	71		
TF, TX 65-60-85	30	40		87.8	88	90	90.5	89.5	88.5	85	83	79
TF, TX 65-60-100	37	50		107.6	106	105	104	103	102	100	99.5	94

Installation sketch

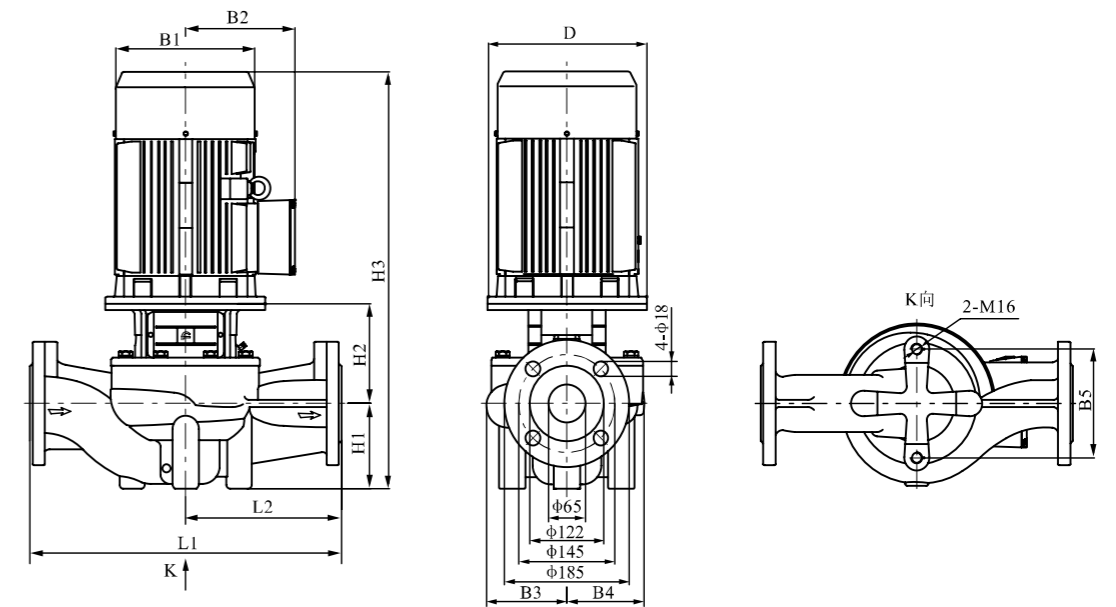

Size and weight

Model (3500rpm)	Size (mm)											Weight (kg)
	D	B1	B2	B3	B4	B5	H1	H2	H3	L1	L2	
TF, TX 65-30-20	160	197	165	142	124	144	105	191	641	360	180	74
TF, TX 65-30-25	160	230	188	142	124	144	105	191	651	360	180	81
TF, TX 65-30-32	200	260	208	142	124	144	105	213	708	360	180	105
TF, TX 65-35-38	200	260	208	142	124	144	105	213	708	360	180	108
TF, TX 65-35-46	350	330	255	179	167	144	125	262	887	475	238	183
TF, TX 65-35-55	350	330	255	179	167	144	125	262	887	475	23S	193
TF, TX 65-50-60	350	330	255	179	167	144	125	262	937	475	238	210
TF, TX 65-50-73	350	330	255	179	167	144	125	262	962	475	238	248
TF, TX 65-60-85	400	400	310	179	167	144	125	262	1037	475	238	309
TF, TX 65-60-100	400	400	310	179	167	144	125	262	1037	475	23S	328

TF, TX 80 60Hz

Performance curve ISO9906:2012, 3B

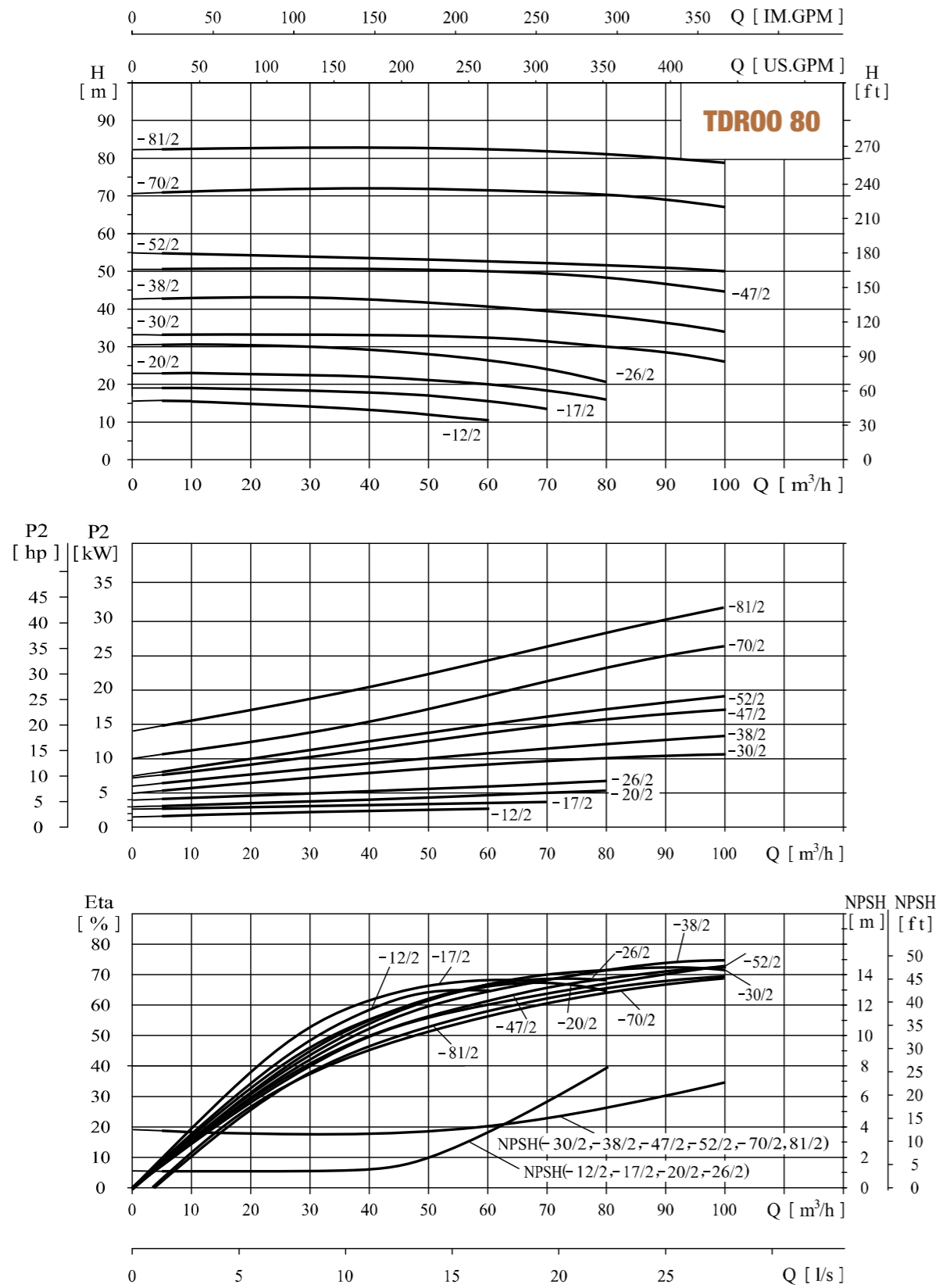

Performance table

Model (3500rpm)	Driving motor (kW)		Q (m³/h)	5	10	20	30	40	50	60	70	80	90	100
	(kW)	(hp)												
TF, TX 80-50-12	3	4		15.2	15.6	15	14.5	13.5	12	10.5				
TF, TX 80-50-17	4	5.5		18.5	19	18.6	18.1	17.5	17	15.8	13.5			
TF, TX 80-60-20	5.5	7.5		22.5	23	23.6	22.8	22	21.2	20	19	16		
TF, TX 80-60-26	7.5	10		30.3	30.6	30.4	30	29	28	26	25	21		
TF, TX 80-80-30	11	15		36.8	36.8	36.7	35.8	35.3	34.2	33.1	32.4	30	27.8	23.5
TF, TX 80-80-38	15	20		42.9	43	43.1	43	42.6	42	40.5	39.5	38	36.2	32.3
TF, TX 80-80-47	18.5	25		51.3	51.5	50.9	50.5	50.3	50.2	50	49.4	47	46.5	44.6
TF, TX 80-80-52	22	30		54.7	55.5	55.2	55	54.8	54.5	54.3	53.4	52	50.5	50
TF, TX 80-80-70	30	40		70.9		71.4		72	71.9	71.6	71	70	69.3	65
TF, TX 80-80-81	37	50		81.9		82.8		82.9		82.5	82.4	81	80	78

Installation sketch

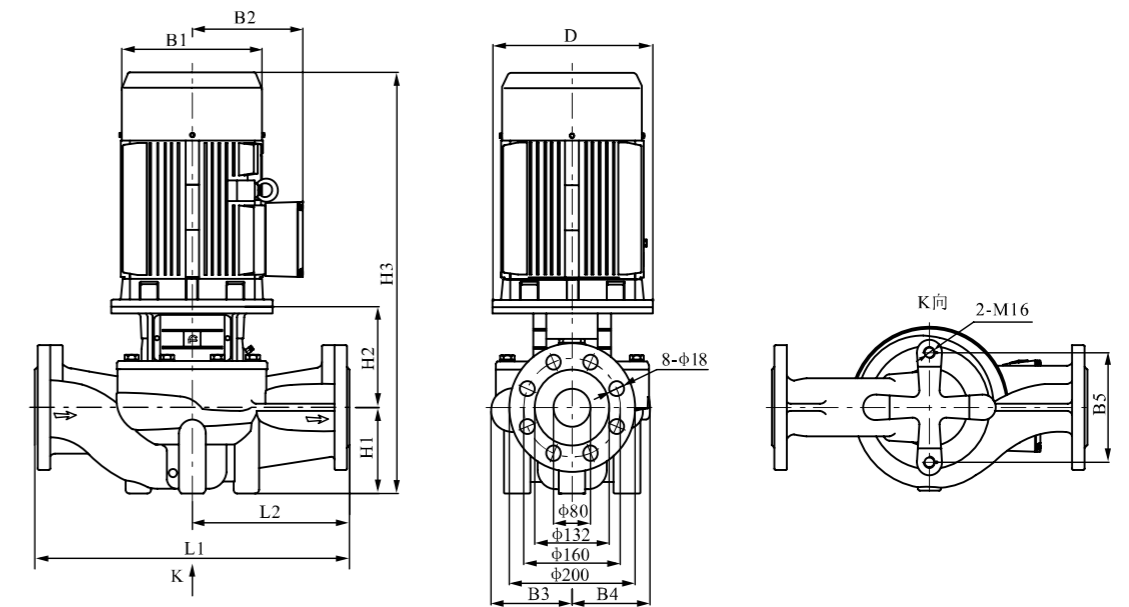

Size and weight

Model (3500rpm)	Size (mm)											Weight (kg)
	D	B1	B2	B3	B4	B5	H1	H2	H3	L1	L2	
TF, TX 80-50-12	160	197	165	142	124	160	97	219	661	450	225	84
TF, TX 80-50-17	160	230	188	142	124	160	97	219	671	450	225	91
TF, TX 80-60-20	160	260	210	142	124	160	97	241	728	450	225	114
TF, TX 80-60-26	160	260	210	142	124	160	97	241	728	450	225	117
TF, TX 80-80-30	350	330	255	182	163	144	115	279	894	500	250	194
TF, TX 80-80-38	350	330	255	182	163	144	115	279	894	500	250	204
TF, TX 80-80-47	350	330	255	182	163	144	115	279	944	500	250	222
TF, TX 80-80-52	350	330	255	182	163	144	115	279	969	500	250	258
TF, TX 80-80-70	400	400	310	182	163	144	115	279	1044	500	250	319
TF, TX 80-80-81	400	400	310	182	163	144	115	279	1044	500	250	338

TF, TX 100 60Hz

Performance curve ISO9906:2012, 3B

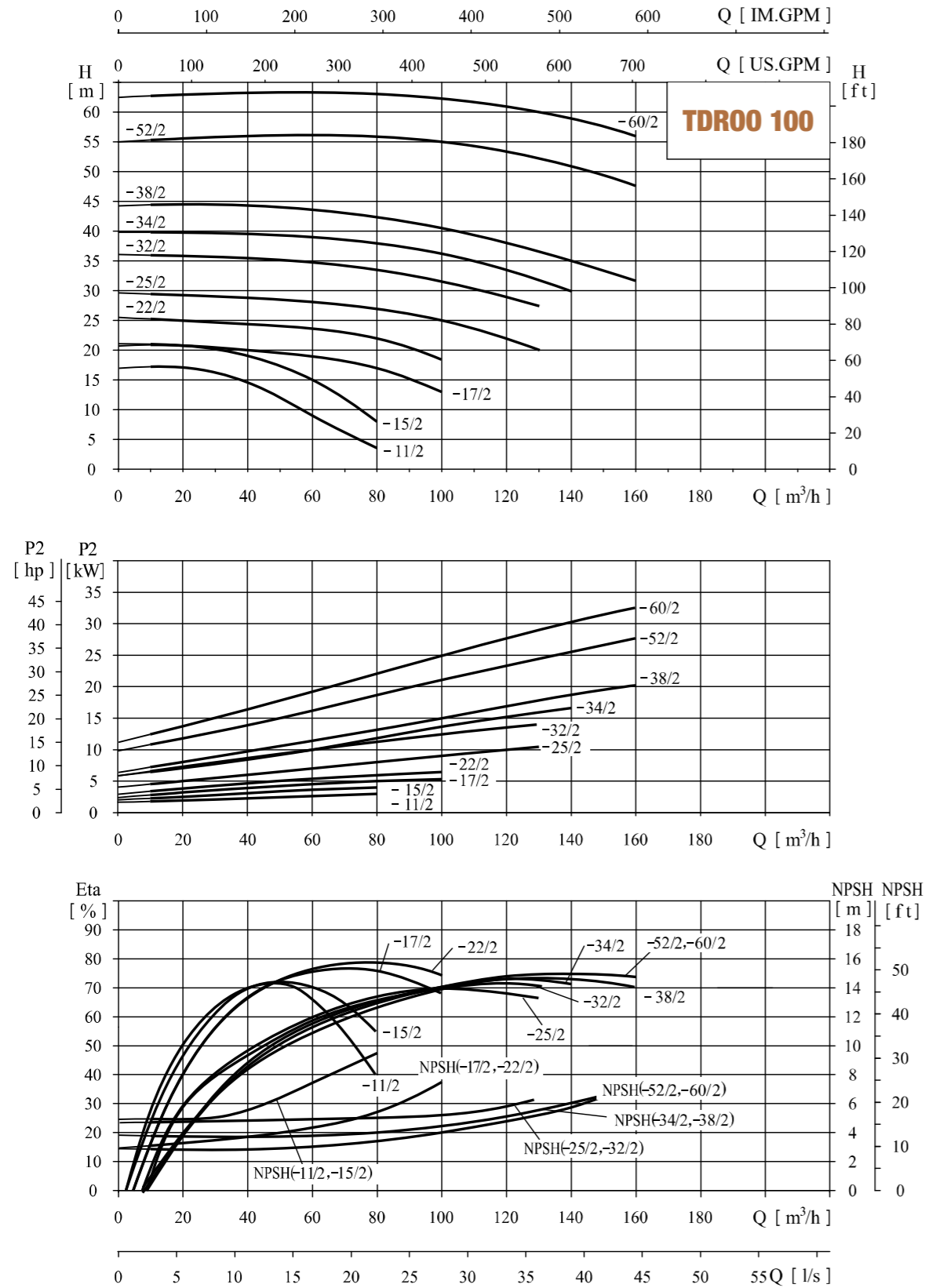

Performance table

Model (3500rpm)	Driving motor (kW)		Q (m³/h)	10	20	40	50	60	80	100	120	130	140	160
	(kW)	(hp)												
TF, TX 100-50-11	3	4		17.2	17.1	14.6	11	9	6.3					
TF, TX 100-60-15	4	5.5		20.7	20.8	17.9		15						
TF, TX 100-80-17	5.5	7.5		21.1	20.8	20		19.2	17	13				
TF, TX 100-80-22	7.5	10		25.6	25.4	24.4		23.5	22	18.4				
TF, TX 100-100-25	11	15		29.1	29.5	28.8		27.8	26.6	25	19.8	19.4		
TF, TX 100-100-32	15	20		36	36.6	35.6		34.6	33.5	32	28.9	25.5		
TF, TX 100-120-34	18.5	25		39.4	39.4	39.5		39	37.8	36.2	34	33.4	31	
TF, TX 100-120-38	22	30		43.7	44.5	44.2		43.8	42.5	40.5	38	36.4	35	30.8
TF, TX 100-130-52	30	40		55	55.8	55.9		55.9	55.5	55	53.6	52	50.9	47.6
TF, TX 100-130-60	37	50		62	62.9	63.3		63.2	63	62	60.6	60	57.6	54

Installation sketch

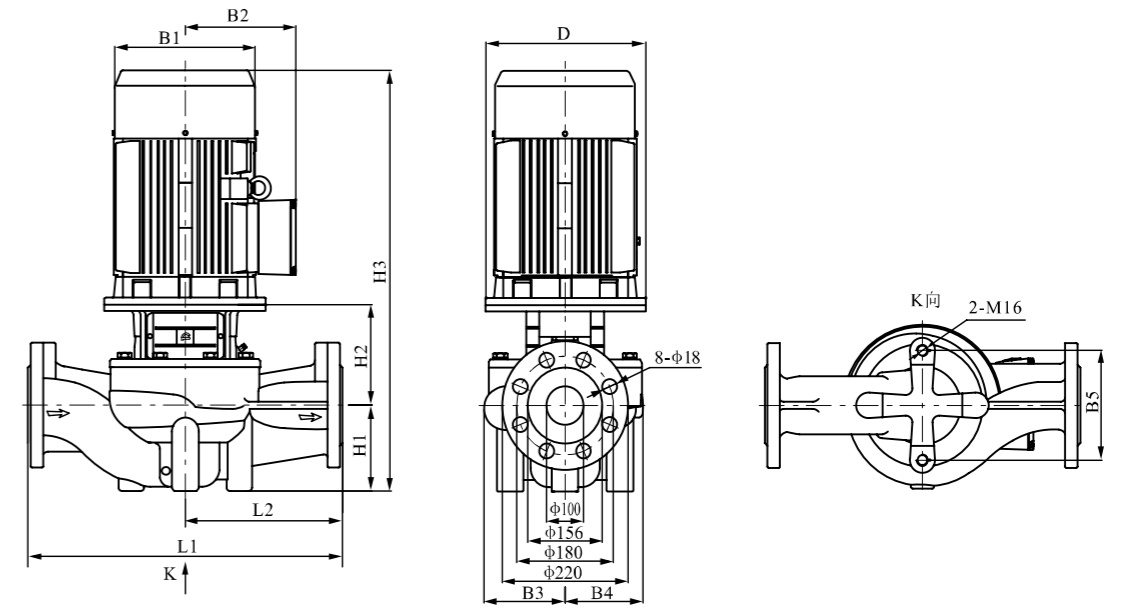

Size and weight

Model (3500rpm)	Size (mm)											Weight (kg)
	D	B1	B2	B3	B4	B5	H1	H2	H3	L1	L2	
TF, TX 100-50-11	160	215	190	134	101	160	105	190	640	450	225	65
TF, TX 100-60-15	160	215	190	134	101	160	105	190	650	450	225	83
TF, TX 100-80-17	200	260	205	150	117	144	140	215	745	500	250	119
TF, TX 100-80-22	200	260	205	150	117	144	140	215	745	500	250	122
TF, TX 100-100-25	350	350	245	181	152	230	140	270	910	550	275	197
TF, TX 100-100-32	350	350	265	181	152	230	140	270	910	550	275	207
TF, TX 100-120-34	350	350	265	181	152	230	140	270	960	550	275	224
TF, TX 100-120-38	350	350	280	181	152	230	140	270	985	550	275	260
TF, TX 100-130-52	400	400	305	181	152	230	140	270	1060	550	275	318
TF, TX 100-130-60	400	400	305	181	152	230	140	270	1060	550	275	337

TF, TX 125 60Hz

Performance curve ISO9906:2012, 3B

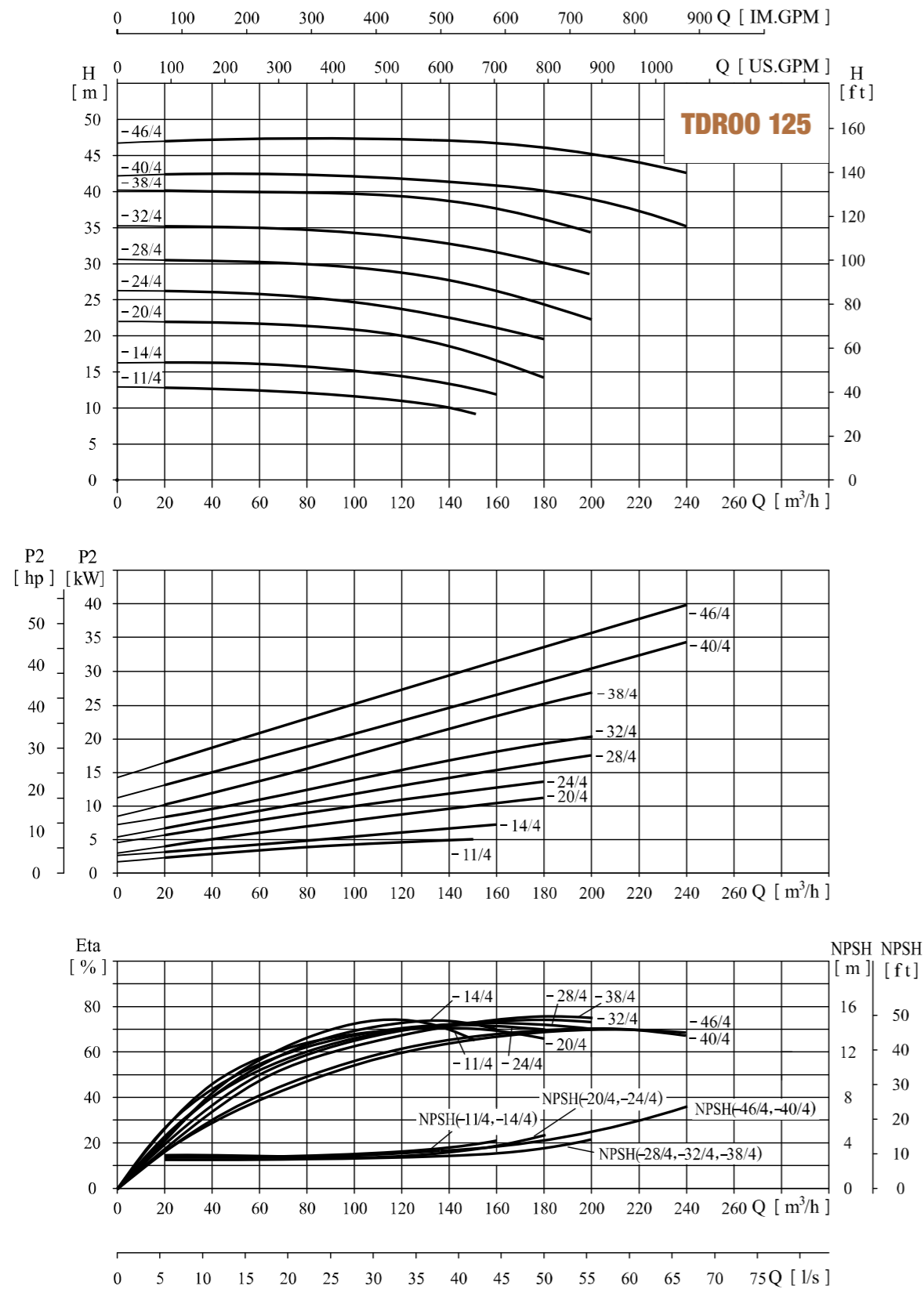

Performance table

Model (1750rpm)	Driving motor (kW)		Q (m³/h)	H (m)													
	(kW)	(hp)		20	40	60	80	100	120	140	150	160	180	200	220	240	
TF, TX 125-120-11	5.5	7.5		12.9	12.7	12.6	12.2	11.6	11	10	9						
TF, TX 125-120-14	7.5	10		16.2	16.1	16	15.9	15.3	14	13.8		12.5					
TF, TX 125-120-20	11	15		21.8	21.4	21.2	21	20.6	20	18		16.4	14.5				
TF, TX 125-120-24	15	20		26.2	25.9	25.7	25.5	24.8	24	22.9		21.2	19.8				
TF, TX 125-140-28	18.5	25		30.4	30.2	30.1	29.9	29.4	28.6	28		26.6	24.5	22.5			
TF, TX 125-150-32	22	30		35.2	34.9	34.8	34.5	34.2	33.5	32.7	32	31.3	30.1	27.8			
TF, TX 125-150-38	30	40		40.2	40.1	40	39.9	39.8	39.5	38.6	38	37.8	36.2	33.8			
TF, TX 125-180-40	37	50		42.6	42.8	42.9	42.7	42.4	41.9	41.3		40.7	40	38.9	37.4	35.6	
TF, TX 125-180-46	45	60		47.2	47.4	47.6	47.7	47.6	47.5	47.2		46.7	46	45.1	44.1	42.8	

Installation sketch

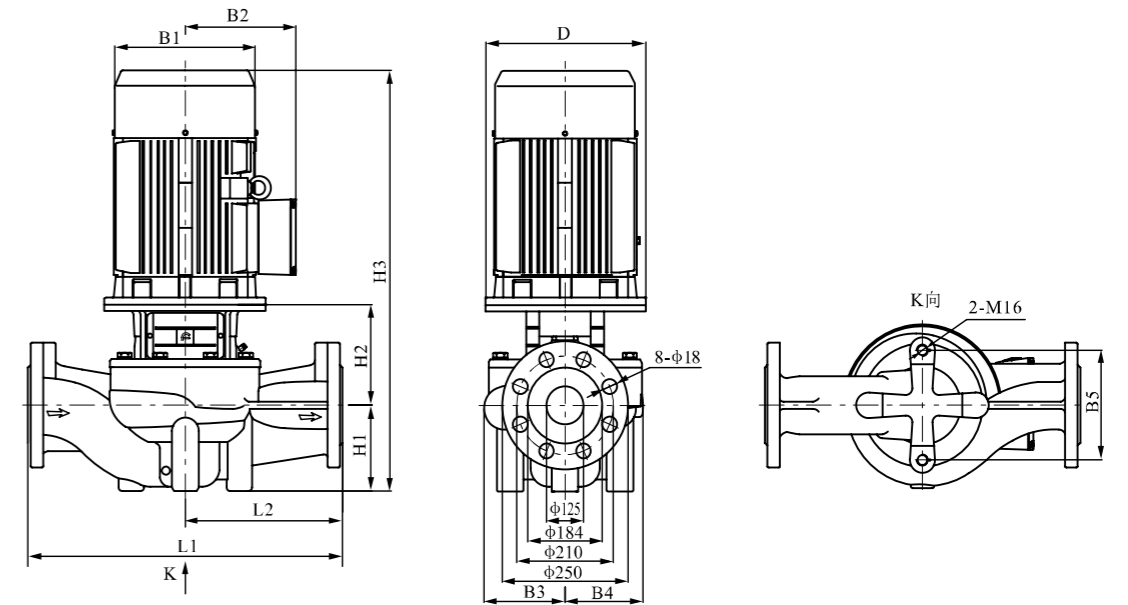

Size and weight

Model (1750rpm)	Size (mm)											Weight (kg)
	D	B1	B2	B3	B4	B5	H1	H2	H3	L1	L2	
TF, TX 125-120-11	200	260	208	216	176	230	215	228	832	620	310	166
TF, TX 125-120-14	200	260	208	216	176	230	215	228	832	620	310	169
TF, TX 125-120-20	350	330	255	236	208	230	215	298	1011	800	400	292
TF, TX 125-120-24	350	330	255	236	208	230	215	298	1053	800	400	302
TF, TX 125-140-28	350	330	255	236	208	230	215	298	1090	800	400	321
TF, TX 125-150-32	350	330	255	236	208	230	215	298	1128	800	400	356
TF, TX 125-150-38	400	400	310	236	208	230	215	298	1162	800	400	416
TF, TX 125-180-40	450	450	325	272	248	230	215	314	1203	800	400	499
TF, TX 125-180-46	450	450	325	272	248	230	215	314	1226	800	400	536

TF, TX 150 60Hz

Performance curve ISO9906:2012, 3B

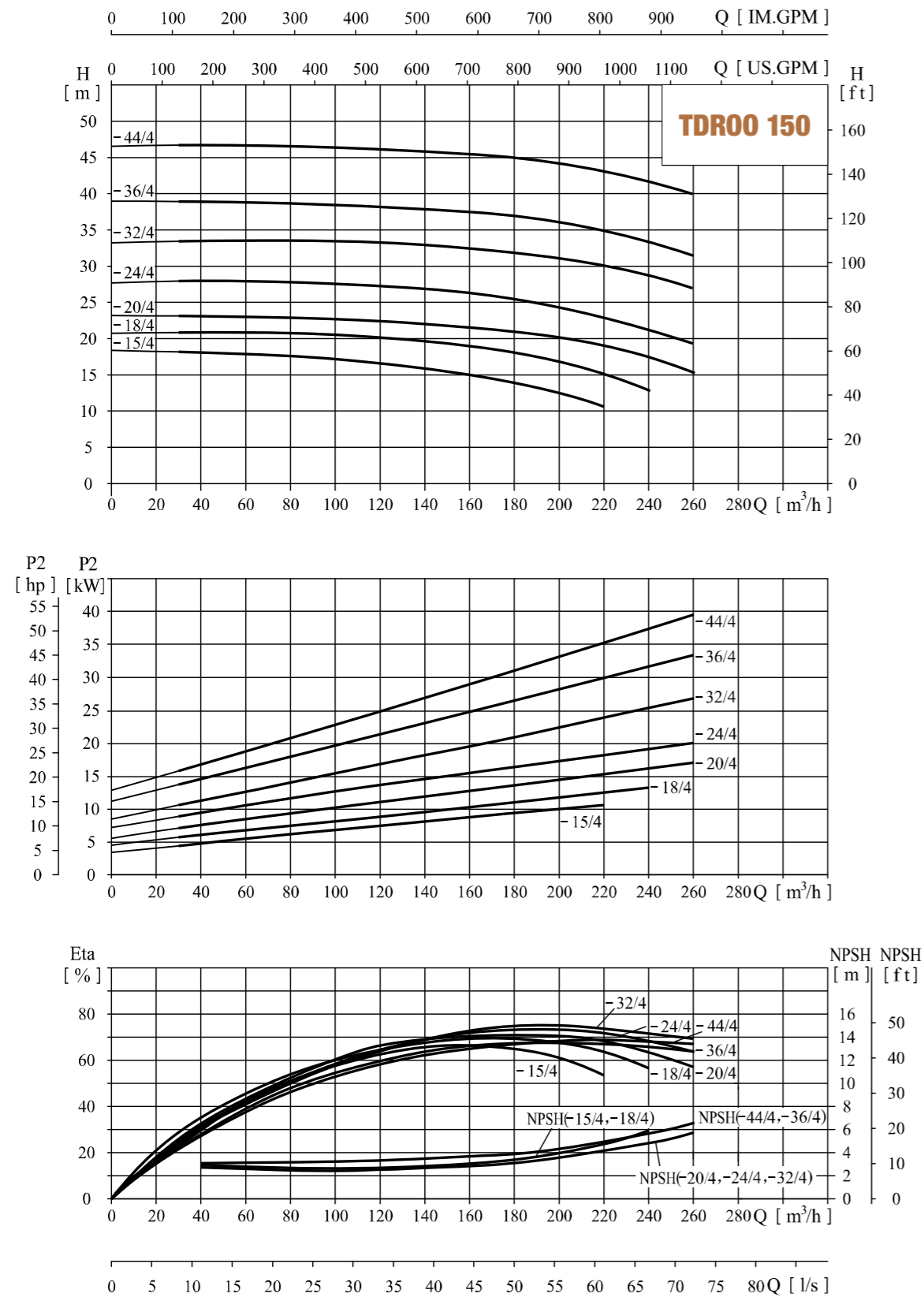

Performance table

Model (1750rpm)	Driving motor (kW)		Q (m³/h)	30	60	90	120	140	160	180	200	220	240	260
	(kW)	(hp)												
TF, TX 150-160-15	11	15	H (m)	19.1	18.4	17.6	16.7	15.9	15	14.1	12.7	10.5		
TF, TX 150-180-18	15	20		21.6	21.3	20.8	20.1	19.5	18.8	18	16.9	15.4	12.6	
TF, TX 150-200-20	18.5	25		24	23.6	23.3	22.9	22.4	21.7	20.9	20	18.9	17.4	15.6
TF, TX 150-200-24	22	30		27	27.2	27.1	26.8	26.3	25.8	24.9	24	22.8	21.5	19.9
TF, TX 150-200-32	30	40		34.2	34.4	34.6	34.4	34	33.5	32.8	32	30.9	29.4	27.3
TF, TX 150-200-36	37	50		39.7	39.3	38.8	38.2	37.8	37.3	36.7	36	34.9	33.6	31.9
TF, TX 150-200-44	45	60		47.3	47.4	47.2	46.8	46.4	45.8	45	44	42.9	41.7	40.2

Installation sketch

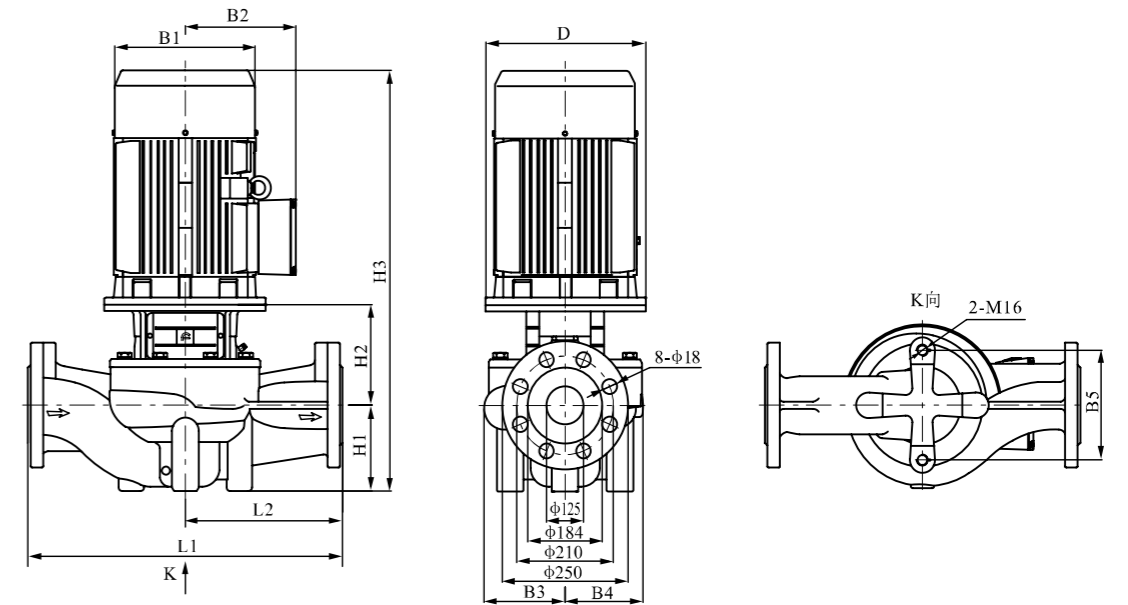

Size and weight

Model (1750rpm)	Size (mm)											Weight (kg)
	D	B1	B2	B3	B4	B5	H1	H2	H3	L1	L2	
TF, TX 150-160-15	350	315	250	238	208	230	215	269	982	800	400	280
TF, TX 150-180-18	350	315	250	238	208	230	215	269	1024	800	400	300
TF, TX 150-200-20	350	360	275	238	208	230	215	269	1061	800	400	336
TF, TX 150-200-24	350	360	275	238	208	230	215	269	1099	800	400	352
TF, TX 150-200-32	400	400	305	238	208	230	215	269	1133	800	400	403
TF, TX 150-200-36	450	450	325	267	248	230	230	288	1192	900	450	508
TF, TX 150-200-44	450	450	325	267	248	230	230	288	1215	900	450	545

TF, TX 200 60Hz

Performance curve ISO9906:2012, 3B

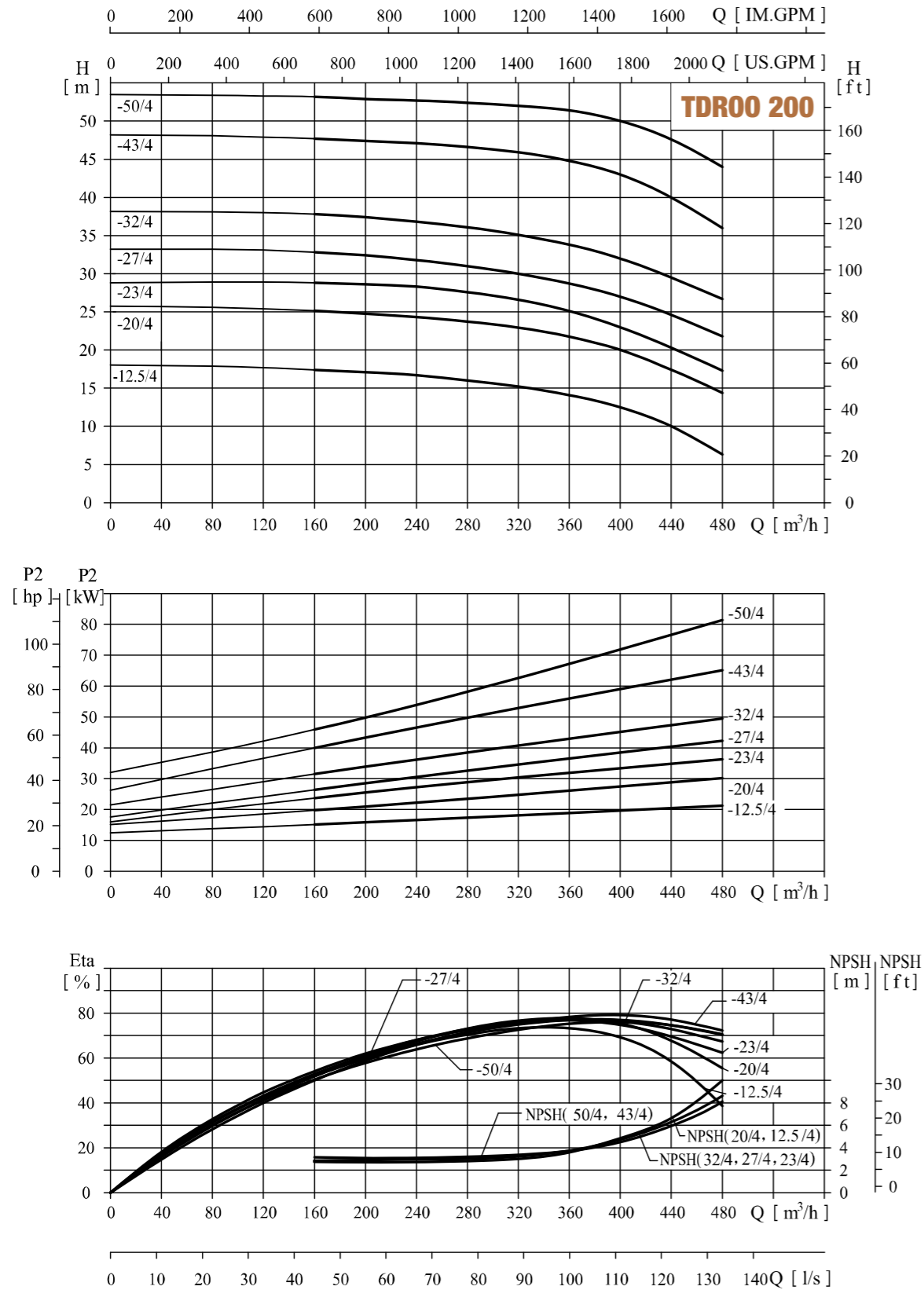

Performance table

Model (1750rpm)	Driving motor (kW)		Q (m³/h)	160	200	240	280	320	360	400	440	480
	(kW)	(hp)										
TF, TX 200-400-12.5	22	30	H (m)	17.4	17.1	16.7	16	15.2	14.1	12.5	10	6.3
TF, TX 200-400-20	30	40		25.1	24.8	24.3	23.8	23	21.8	20	17.5	14.9
TF, TX 200-400-23	37	50		28.8	28.6	28.3	27.6	26.6	25.1	23	20.3	17.3
TF, TX 200-400-27	45	60		32.8	32.4	31.8	31	30	28.7	27	24.6	21.8
TF, TX 200-400-32	55	75		37.8	37.4	36.8	36.1	35.1	33.8	32	29.5	26.7
TF, TX 200-400-43	75	100		47.7	47.4	47.1	46.6	45.9	44.8	43	40	36
TF, TX 200-400-50	90	120		53.2	52.9	52.7	52.4	52	51.4	50	47.6	44

Installation sketch

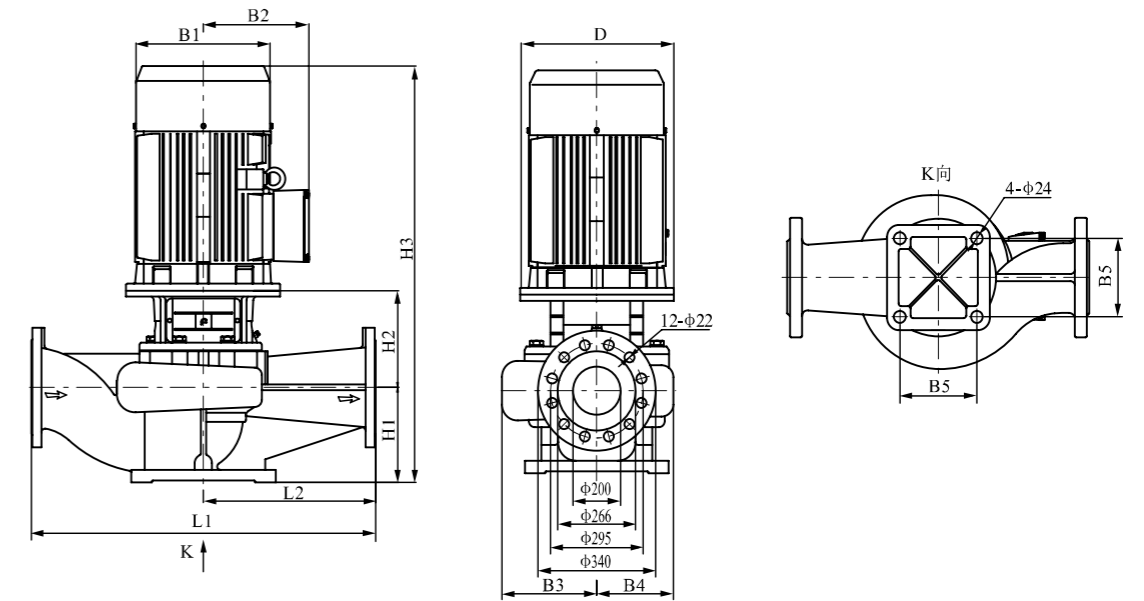

Size and weight

Model (1750rpm)	Size (mm)											Weight (kg)
	D	B1	B2	B3	B4	B5	H1	H2	H3	L1	L2	
TF, TX 200-400-12.5	350	360	280	278	219	360	270	415	1300	1000	500	431
TF, TX 200-400-20	400	400	305	278	219	360	270	415	1334	1000	500	490
TF, TX 200-400-23	450	450	335	303	252	360	270	445	1389	1100	550	600
TF, TX 200-400-27	450	450	335	303	252	360	270	445	1412	1100	550	636
TF, TX 200-400-32	550	490	365	303	252	360	270	445	1488	1100	550	707
TF, TX 200-400-43	550	550	400	315	269	360	270	457	1556	1100	550	880
TF, TX 200-400-50	550	550	400	315	269	360	270	457	1607	1100	550	971

TF, TX 250 60Hz

Performance curve ISO9906:2012, 3B

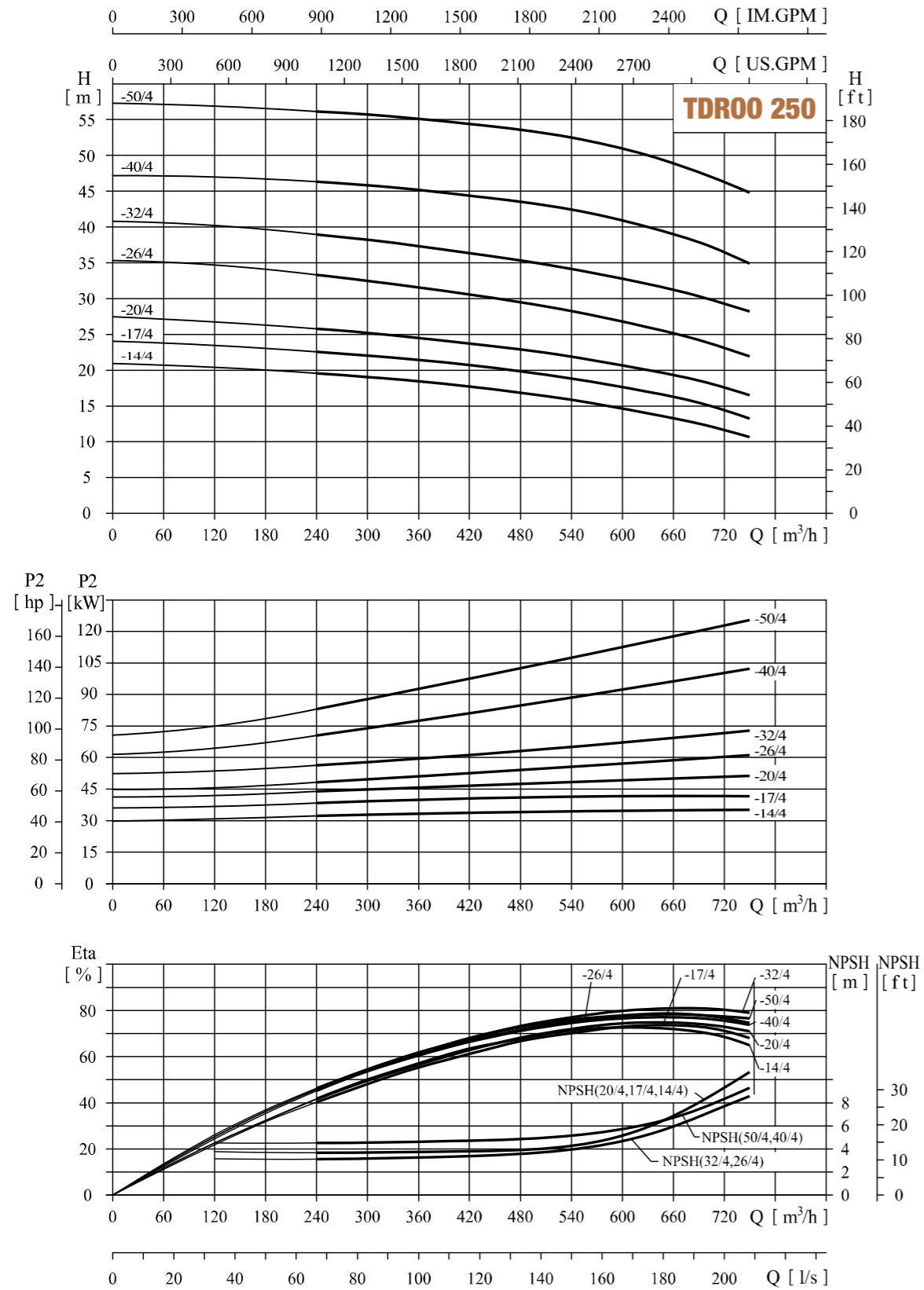

Performance table

Model (1750rpm)	Driving motor (kW)		Q (m³/h)	240	300	360	420	480	540	600	630	660	720	750
	(kW)	(hp)												
TF, TX 250-630-14	37	50	H (m)	19.6	19.1	18.4	17.7	16.8	15.9	14.7	14	13.3	11.6	10.7
TF, TX 250-630-17	45	60		22.5	22.1	21.4	20.7	19.9	18.9	17.6	17	16.3	14.4	13.2
TF, TX 250-630-20	55	75		25.8	25.2	24.5	23.7	22.9	21.9	20.7	20	19.3	17.6	16.5
TF, TX 250-630-26	75	100		33.3	32.5	31.5	30.6	29.5	28.2	26.8	26	25.2	23.1	21.9
TF, TX 250-630-32	90	120		38.9	38.2	37.3	36.3	35.3	34.2	32.8	32	31.2	29.3	28.2
TF, TX 250-630-40	110	150		46.4	45.8	45.2	44.4	43.6	42.4	40.9	40	39	36.5	34.9
TF, TX 250-630-50	132	180		56.1	55.7	55.1	54.4	53.6	52.5	50.9	50	48.9	46.3	44.8

Installation sketch

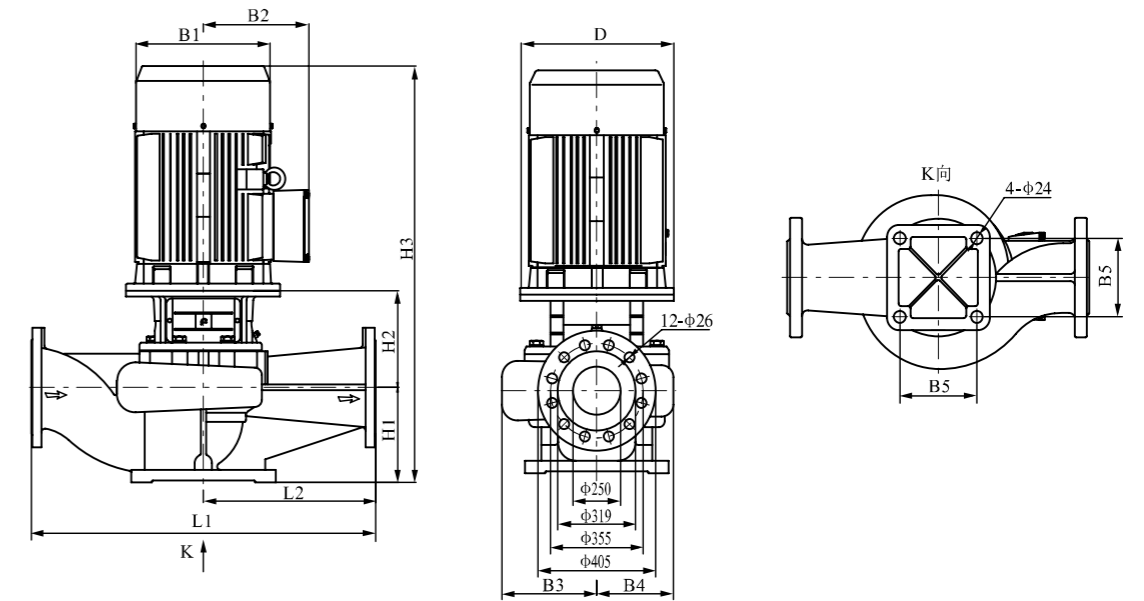

Size and weight

Model (1750rpm)	Size (mm)											Weight (kg)
	D	B1	B2	B3	B4	B5	H1	H2	H3	L1	L2	
TF, TX 250-630-14	450	450	335	316	243	390	300	495	1469	1100	550	610
TF, TX 250-630-17	450	450	335	316	243	390	300	495	1492	1100	550	647
TF, TX 250-630-20	550	490	365	316	243	390	300	495	1568	1100	550	720
TF, TX 250-630-26	550	550	400	329	264	440	300	507	1636	1100	550	906
TF, TX 250-630-32	550	550	400	329	264	440	300	507	1687	1100	550	997
TF, TX 250-630-40	660	625	555	347	292	440	305	525	1840	1200	600	1386
TF, TX 250-630-50	660	625	555	347	292	440	305	525	1990	1200	600	1469

TF, TX 300 60Hz

Performance curve ISO9906:2012, 3B

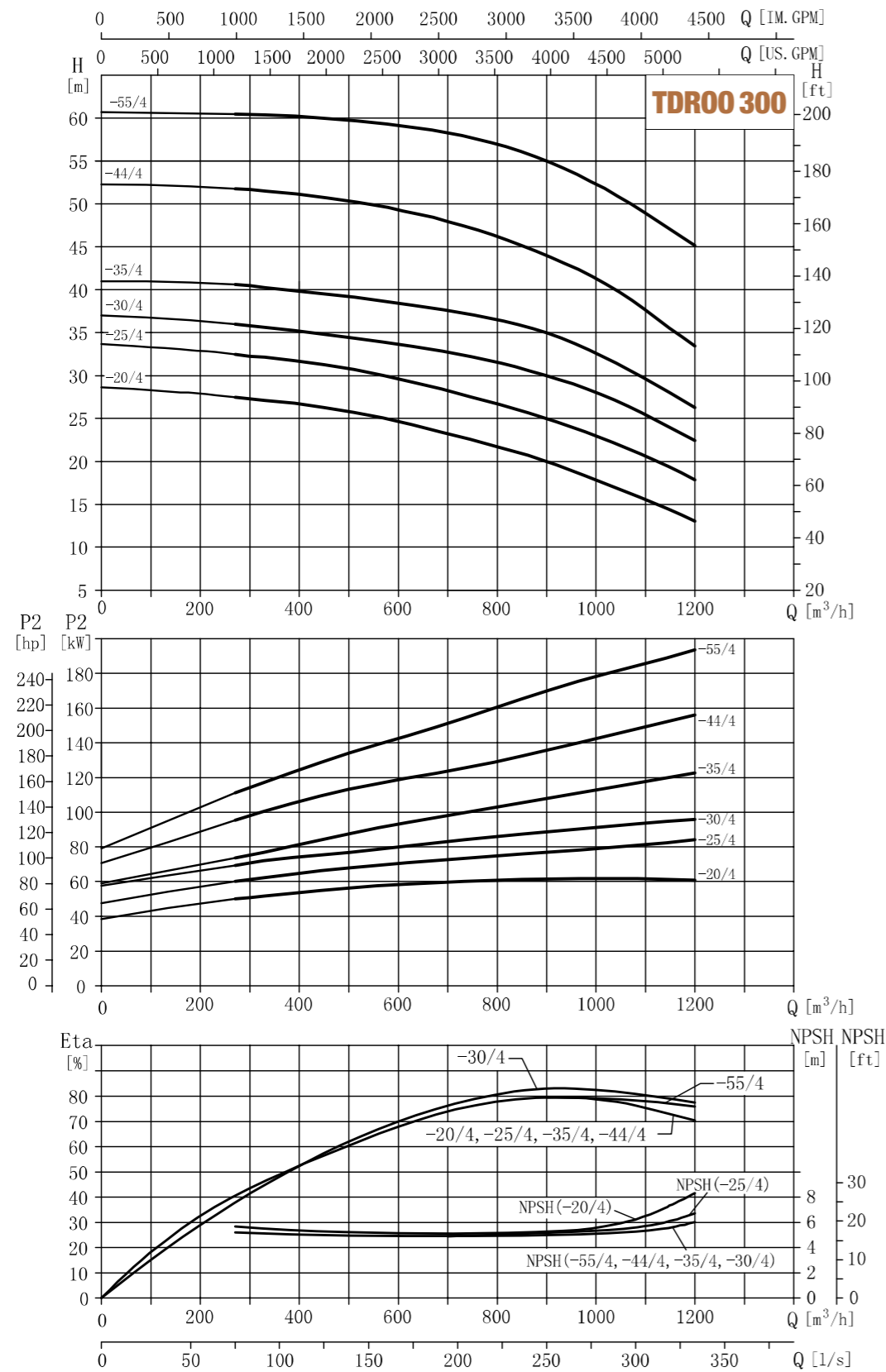

Performance table

Model (1750rpm)	Driving motor (kW)		Q (m³/h)	270	360	450	630	750	900	1080	1200
	(kW)	(hp)									
TF, TX 300-900-20	75	100	H (m)	27.5	27	26.3	24.3	22.5	20	16	13
TF, TX 300-900-25	90	120		32.5	32	31.3	29.3	27.6	25	21.1	17.9
TF, TX 300-900-30	110	150		36	35.4	34.8	33.4	32.1	30	26	22.4
TF, TX 300-900-35	132	180		40.6	40	39.6	38.2	37	35	30.2	26.3
TF, TX 300-900-44	160	215		51.8	51.3	50.7	49	47.1	44	38.5	33.5
TF, TX 300-900-55	200	270		60.5	60.3	60	58.9	57.7	55	49.6	45

Installation sketch

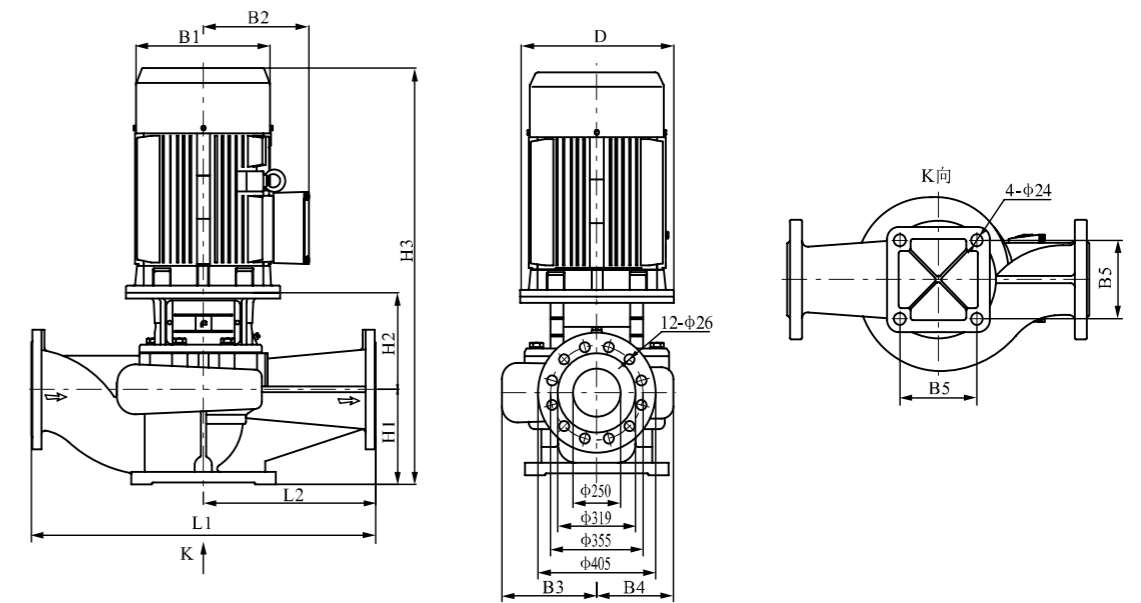

Size and weight

Model (1750rpm)	Size (mm)											Weight (kg)
	D	B1	B2	B3	B4	B5	H1	H2	H3	L1	L2	
TF, TX 300-900-20	550	550	400	345	250	440	290	649	1770	1200	600	1070
TF, TX 300-900-25	550	550	400	345	250	440	290	649	1820	1200	600	1120
TF, TX 300-900-30	660	625	550	345	250	440	290	679	2200	1200	600	1460
TF, TX 300-900-35	660	625	550	345	250	440	290	679	2150	1200	600	1540
TF, TX 300-900-44	660	625	550	380	295	480	290	702	2150	1200	600	1780
TF, TX 300-900-55	660	625	550	380	295	480	290	702	2150	1200	600	1900

Notes

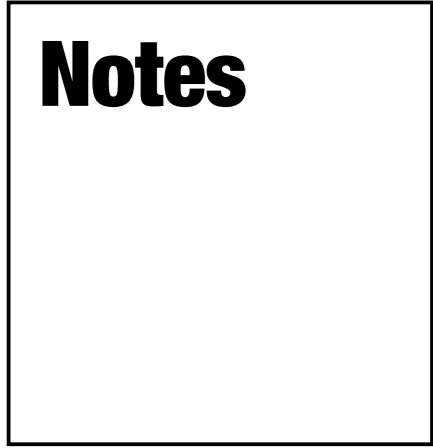

A series of horizontal dotted lines for writing notes, extending across the left half of the page.

A series of horizontal dotted lines for writing notes, extending across the right half of the page.

hydroo®

Be pumping partners

HYDROO
Pump Industries SL

Carrer La Banyeta Nova, 11
Polígon Industrial La Banyeta
17843 Palol de Revardit
Catalonia. Spain
Tel. +34 972 394 654
E-mail: info@hydroo.com
www.hydroo.com

201830-CTL-TDROO-EN
subject to amendments

